

AMALY screen 32"
AMALY screen 36"
AMALY inline 10"
AMALY inline 16"
AMALY inline 24"
AMALY side panel 32"
AMALY side panel 36"
AMALY side panel 42"

ZITTACLEAN

Le micro film protecteur formé lors de son application, fera perler l'eau sur le verre afin d'en faciliter l'entretien.

Il est recommandé de passer la raclette après chaque usage.

The micro protective layer formed during its application will make the water bead along the glass for easy maintenance.

We recommend cleaning the door with the squeegee after each use.

L'ENTRETIEN DE VOTRE DOUCHE

Ne jamais utiliser de poudre ou de tampon à récurer. Il suffit de nettoyer la porte avec une solution d'eau et vinaigre, 1 once vinaigre pour 5 onces d'eau. Vous pouvez utiliser un détergent doux mais aucun produit à base d'ammoniaque cela pourrait endommager la surface de la vitre.

THE MAINTENANCE OF YOUR SHOWER

Never use of powder or scouring pads. Simply clean the door with a solution of water and vinegar, 1 to 5. You can use a mild detergent but never use ammoniac, it could damage the glass surface.

PORTE REVERSIBLE

La porte doit être du même côté que le panneau de retour.

The door must be the same side as the side panel.

REVERSIBLE DOOR

Les instructions montrés au manuel sont pour le montage de la porte droite.

The instructions shown in the manual is for the installation of the right door.



GROUPE ZITTA

GROUP



ACRYLINE

Tel: 1-855-492-4242 450-704-2323

Fax: 1-866-735-6885

Info@zittagroup.com

www.zittagroup.com

81, Theodore-Viau, Terrebonne,
Quebec, Canada, J6Y 0J8

SECTION A

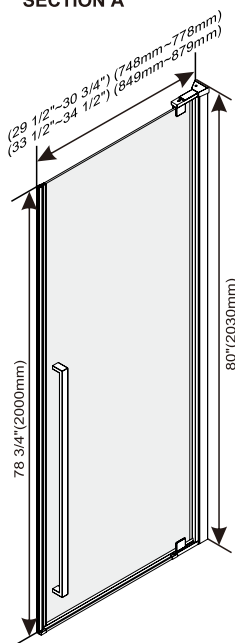

SECTION A1 à to A7 et/and B

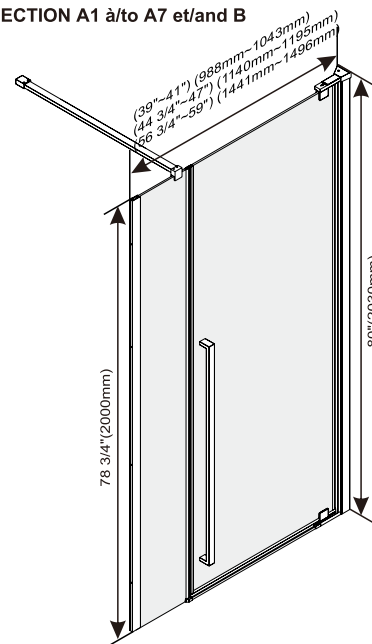

SECTION A1 à to A7 et/and C

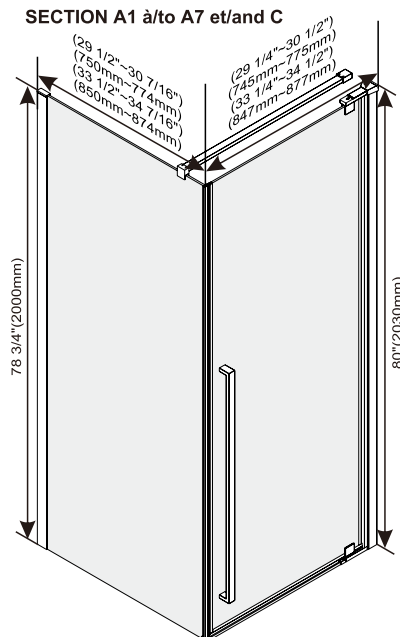

SECTION A1 à to A7 et/and C

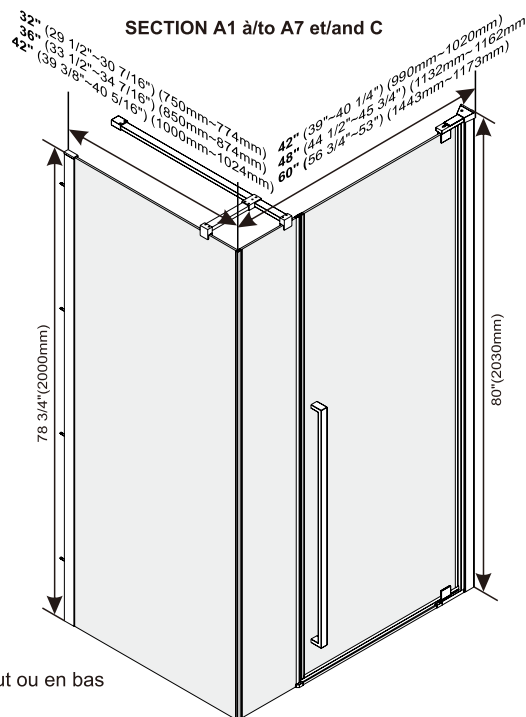

2 possibilité d'installation de la poignée en haut ou en bas
 2 choices install the handle up or down

Les pivots doivent toujours être installer du côté du mur
 The pivots must always be installed on the side of the wall

MANUEL D'INSTALLATION / INSTALLATION MANUAL

IMPORTANT

- Inspecter le produit avant de procéder à l'installation.
- La garantie sera invalide si le produit a été installé avec des défauts apparents.

ATTENTION

- Lors de l'installation, l'application de silicone doit être à l'extérieur de la douche, car si appliqué à l'intérieur, cela peut causer des fuites d'eau !
- Veuillez lire attentivement ce manuel d'instruction avant de commencer l'installation.
- Conserver ce manuel pour référence ultérieure.

IMPORTANT

- Thoroughly inspect your product before proceeding with the installation.
- The warranty will be void if the product is installed with a conspicuous defect.

CAUTION

- To prevent leaks, silicone must be applied on the outside of the shower and not on the inside!
- Read all instructions carefully before starting the installation.
- Save this manual for future reference.

CONTENU / PARTS LIST

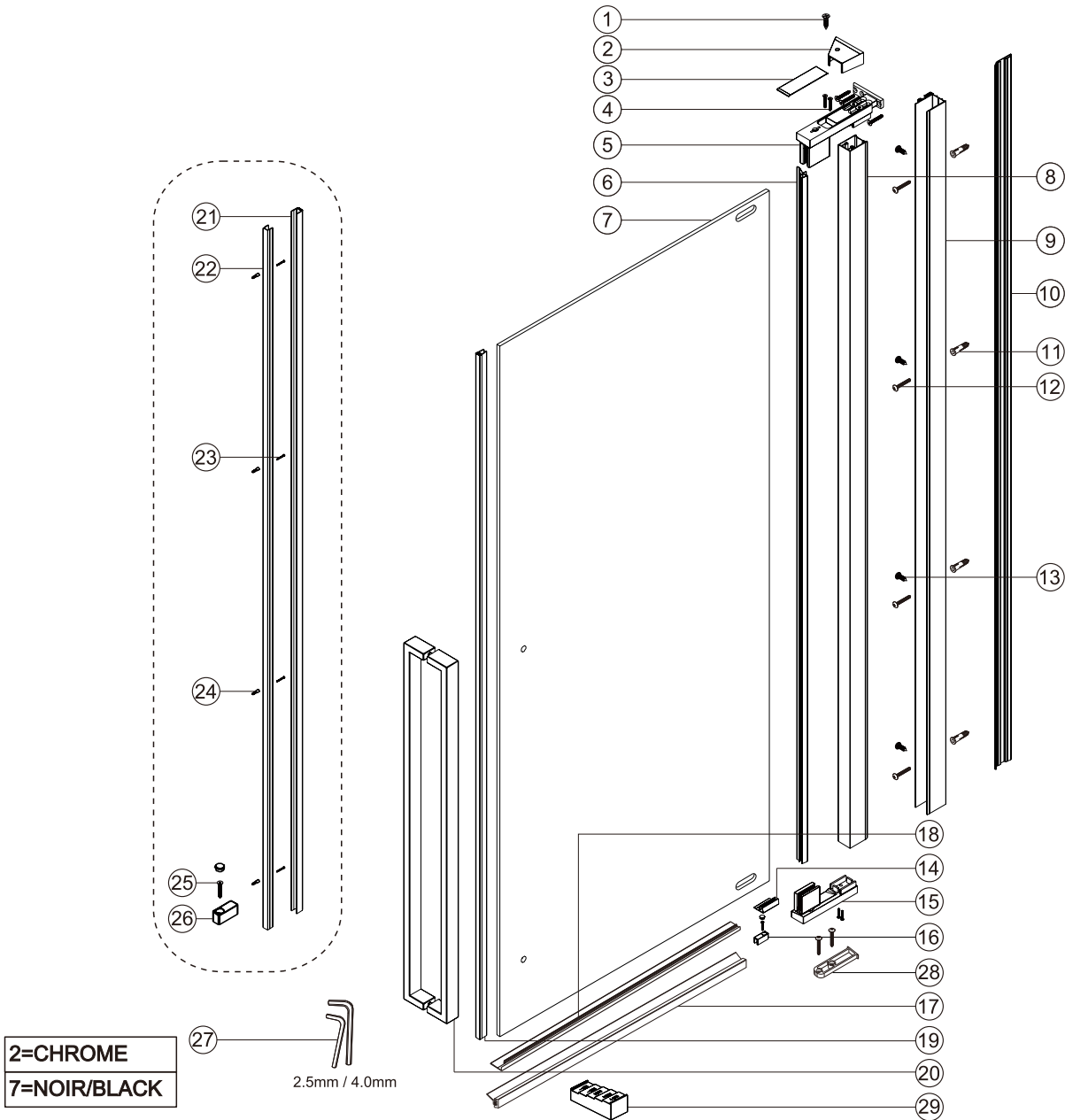

Número NO	Qté Qty	Description Description	32"/42"/48" Code	36"/60" Code	Número NO	Qté Qty	Description Description	32"/42"/48" Code	36"/60" Code
1	1	Vis 8 x 1 Screw 8 x 1	PV001899	PV001899	16	1	Ancrage d'anti éclaboussure avec cap Bracket for backsplash with cap	PQ01560_	PQ01560_
2	1	Couvert d'extrusion mural kit Channel cap extrusion kit	PQ01520_	PQ01520_	17	1	Anti éclaboussure Back splash	PQ01570_	PQ01580_
3	1	Couvert du pivot Pivot cap	PQ01530_	PQ01530_	18	1	Joint anti éclaboussure long Backsplash gasket long	PJ00551_	PJ00561_
4	10	Vis en V 8 x 1 Flat screw 8 x 1	PV001899	PV001899	19	1	Aimant A 78 3/4" 2000mm Magnet A 78 3/4" 2000mm	PJ00311_	PJ00311_
5	1	kit pivot bas et haut Pivot kit top and bottom	PQ01540_	PQ01540_	20	1	Poignée Handle	PP00090_	PP00090_
6	1	Joint d'étanchéité verticale Vertical gasket	PJ00531_	PJ00531_	21	1	Extrusion avec aimant Amaly Channel with magnet Amaly	PA00290_	PA00290_
7	1	Porte de pivot clair Clear pivot door	DG1032SD01	DG1036SD01	22	1	Extrusion mural d'aimant Wall channel for magnet	PA00300_	PA00300_
8	1	Extrusion du pivot Amaly Pivot channel Amaly	PA00260_	PA00260_	23	4	Vis 1 5/8 " tête plate 1 5/8 " flat head screw	PV000299	PV000299
9	1	Extrusion murale Amaly Wall Channel Amaly	PA00270_	PA00270_	24	5	Cheville murale Wall anchor	PV000199	PV000199
10	1	Cap de l'extrusion murale Amaly Wall channel cap Amaly	PA00280_	PA00280_	25	1	Vis en V 8 x 1 Flat screw 8 x 1	PV001899	PV001899
11	10	Cheville murale Wall anchor	PV000199	PV000199	26	1	Ancrage d'anti éclaboussure avec cap Bracket for backsplash with cap	PQ01560_	PQ01560_
12	6	Vis 8 X 1 1/2 " tête plate Flat head screw 8 X 1 1/2 "	PV000799	PV000799	27	1	Kit de clé Allen 2.5mm & 4.0mm 2.5mm & 4.0mm Allen key kit	PT002899	PT002899
13	4	Vis auto perçante 8 x 1/2" Self tapping screw 8 x 1/2"	PV001399	PV001399	28	1	Ancrage d'enlèvement Bottom fixing part	PQ019199	PQ019199
14	1	Joint anti éclaboussure petit Backsplash gasket small	PJ00541_	PJ00541_	29	1	Buté d'installation Installation tool	PT001599	PT001599
15	1	Support a pivot bas et haut Pivot support top and bottom	PQ01550_	PQ01550_					

CONTENU / PARTS LIST

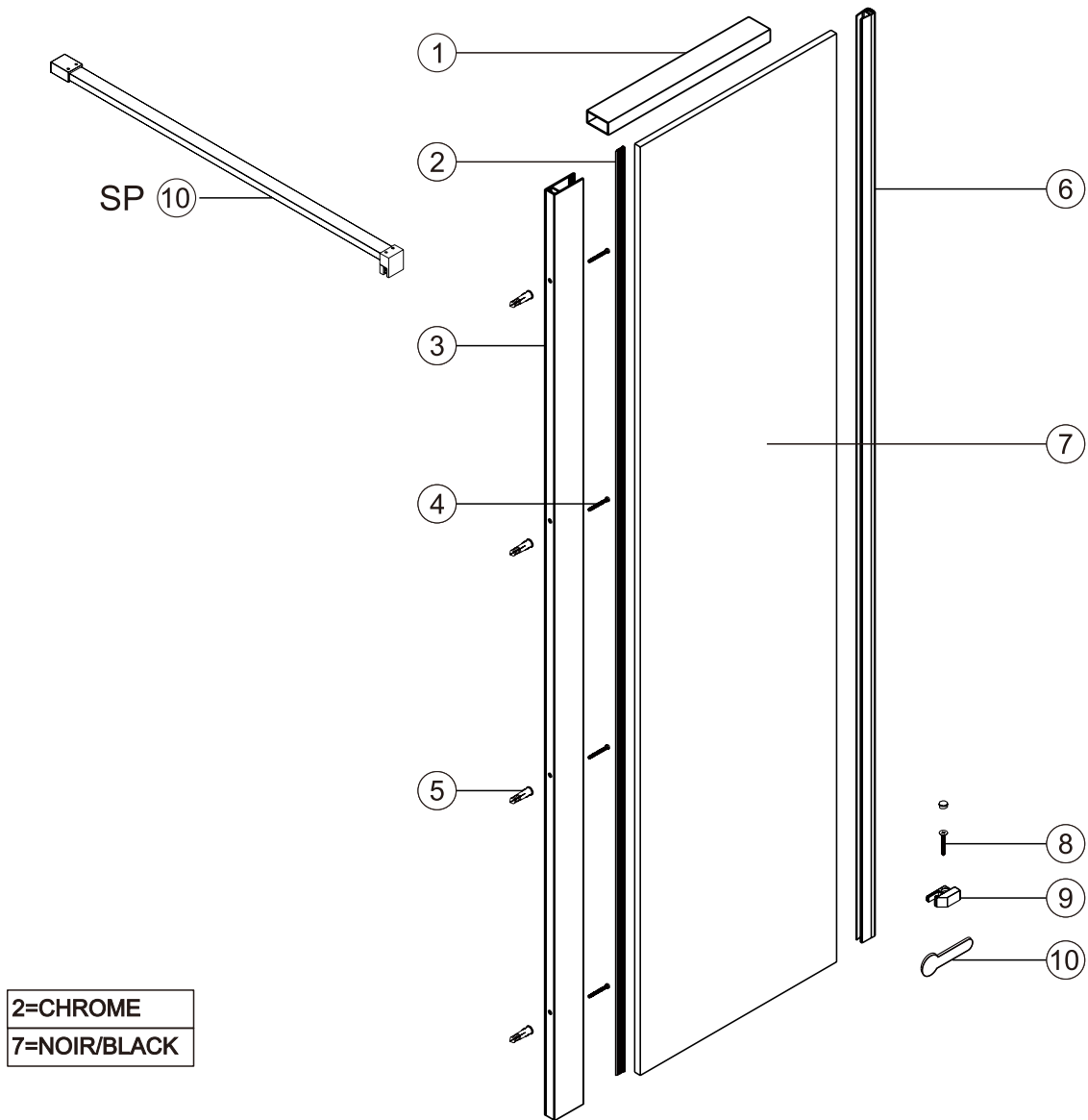

2=CHROME
7=NOIR/BLACK

Numéro NO	Qté Qty	Description Description	10"Code	16"Code	24"Code
1A	1	Barre transversale / cross-bar	PQ01590_	PQ01600_	PQ01610_
1A	1	Attache barre à barre / Bar to bar attachment	PQ01620_	PQ01620_	PQ01620_
1A	1	Attache sur la vitre / Attached on the glass	PQ01630_	PQ01630_	PQ01630_
2	1	Joint de serrage / Squeeze gasket	PJ00571_	PJ00571_	PJ00571_
3	1	Extrusion murale / Chrome Wall	PA00000_	PA00000_	PA00000_
4	5	Vis 8 X 1 1/2 " tête plate / Flat head screw 8 X 1 1/2 "	PV000799	PV000799	PV000799
5	6	Cheville murale / Wall anchor	PV000199	PV000199	PV000199
6	1	Aimant B 8mm 78 3/4" 2000mm Magnet B 8mm 78 3/4" 2000mm	PJ00611_	PJ00611_	PJ00611_
7	1	Panneau fixe / Fix panel	DG1010SF01	PG008420	PG008520
8	1	Vis en V 8 x 1 / Flat screw 8 x 1	PV001899	PV001899	PV001899
9	1	Ancrage pour anti éclaboussure kit Bracket for back splash kit	PQ01640_	PQ01640_	PQ01640_
10	1	Outil pour joint de serrage / Squeeze gasket tool	PT000399	PT000399	PT000399
SP10A	1	Barre d'attache 36 / brace bar 36	PQ01650_	PQ01650_	PQ01650_
SP10A	1	Attache au mur / Attaches to the wall	PQ01660_	PQ01660_	PQ01660_
SP10A	1	Attache sur la vitre / Attached on the glass	PQ01630_	PQ01630_	PQ01630_

CONTENU / PARTS LIST

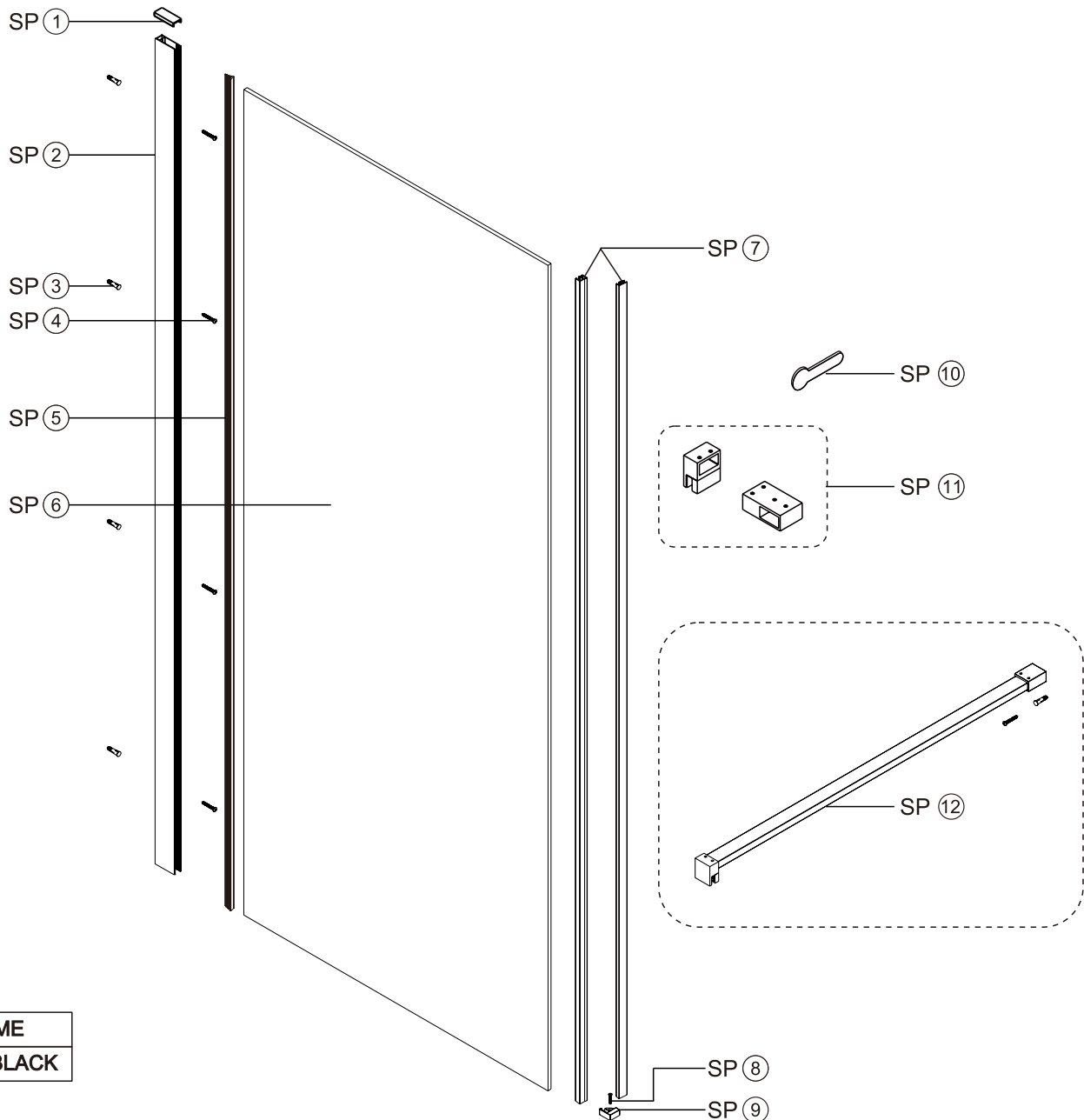

2=CHROME
7=NOIR/BLACK

Numéro NO	Qté Qty	Description Description	Code
SP1	1	Couvert d'extrusion mural Channel cap extrusion	PQ00010_
SP2	1	Extrusion murale Wall Channel	PA00000_
SP3	5	Cheville murale Wall anchor	PV000199
SP4	4	Vis 8 X 1 1/2 " tête plate Flat head screw 8 X 1 1/2 "	PV000799
SP5	1	Joint de serrage Squeeze gasket	PJ00571_
SP6A	1	Panneau de retour clair de retour 8 mm 32" Clear Return panel 8 mm 32"	DG1032RX01
SP6B	1	Panneau de retour clair de retour 8 mm 36" Clear Return panel 8 mm 36"	DG1036RX01
SP6C	1	Panneau de retour clair de retour 8 mm 42" Clear Return panel 8 mm 42"	DG1042RX01
SP7	1	aimant B 90 8mm 2000mm Magnet B 90 8mm 2000mm	PJ00521_
SP8	1	Vis 8 X 1 5/8 " tête en V Flat head screw 8 X 1 5/8 "	PV000699
SP9	1	Ancrage chrome 90 pour anti éclaboussure KIT 90 Chrome bracket for back splash KIT	PQ01670_
SP10	1	Outil pour joint de serrage Squeeze gasket tool	PT000399
SP11A	1	Attache barre à barre Bar to bar attachment	PQ01620_
SP11B	1	Attache sur la vitre Attached on the glass	PQ01630_

Numéro NO	Qté Qty	Description Description	Code
SP12A	1	Barre d'attache 36 Brace bar 36	PQ01650_
SP12A	1	Attache au mur Attaches to the wall	PQ01660_
SP12A	1	Attache sur la vitre Attached on the glass	PQ01630_
SP12A	1	Cheville murale Wall anchor	PV000199
SP12A	1	Vis 8 X 1 1/2 " tête plate Flat head screw 8 X 1 1/2 "	PV000799

Numéro NO	Qté Qty	Description Description	Code
SP12B	1	Barre d'attache 42 brace bar 42	PQ01680_
SP12B	1	Attache au mur Attaches to the wall	PQ01660_
SP12B	1	Attache sur la vitre Attached on the glass	PQ01630_
SP12B	1	Attache au mur Attaches to the wall	PV000199
SP12B	1	Vis 8 X 1 1/2 " tête plate Flat head screw 8 X 1 1/2 "	PV000799

12A Seulement pour installation 32x32 et 36x36 coin
Only for 32x32 and 36x36 installation corner

12B Seulement avec panneau de retour 42
Only with side panel 42

PRÉPARATION/PREPARATION

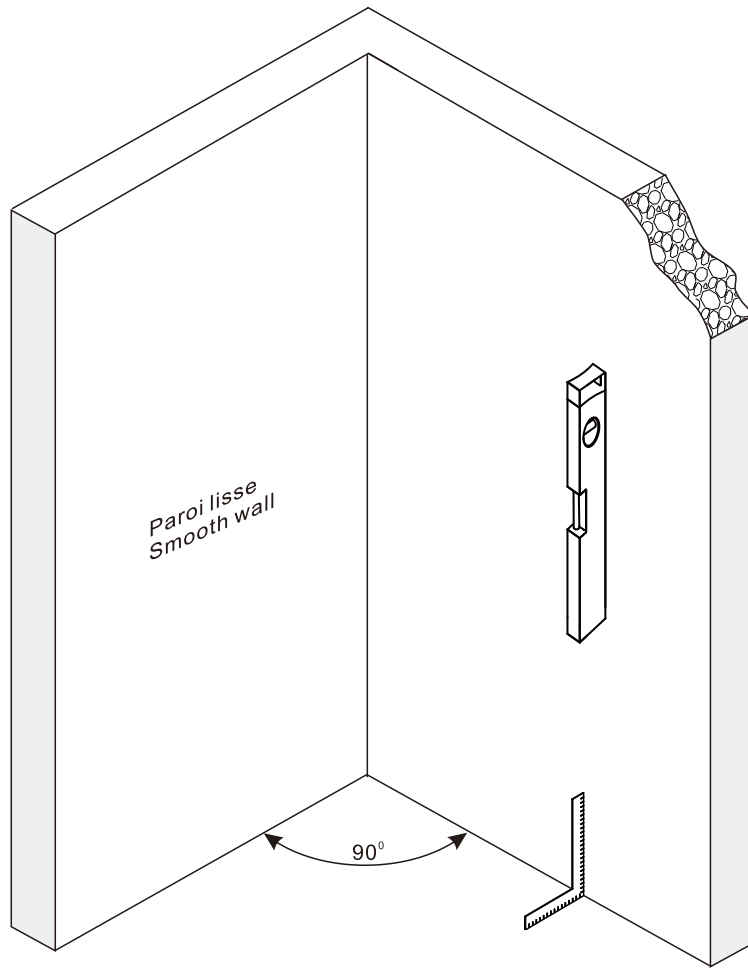

OUTILS ET MATÉRIAUX REQUIS / TOOLS AND MATERIALS REQUIRED

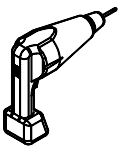

PERCEUSE
DRILL



VIS
SCREWS

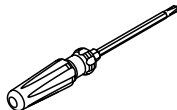

TOURNEVIS
SCREWDR

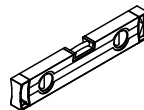

NIVEAU
LEVEL



COUTEAU DE PRECISION
PRECISION KNIFE



SILICONE
SILICONE



FORETS: 1/8", 3/16" ET 1/4"
*FORET À MAÇONNERIE
DRILL BITS: 1/8", 3/16" ET 1/4"
*MASONRY DRILL BIT

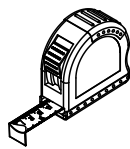

RUBAN À MESURER
MEASURING TAPE



ÉQUERRE
SET SQUARE



CRAYON
PENCIL

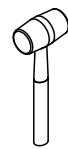

MAILLET
MALLET

SUITE / CONTINUED

A 01

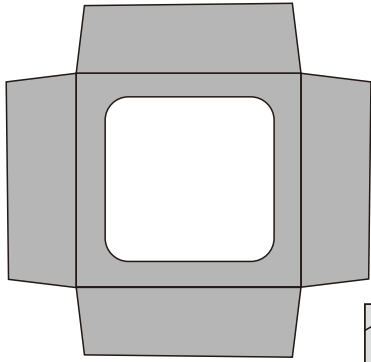

Pour protéger le FINI de votre base de douche.
To protect your shower base finish.

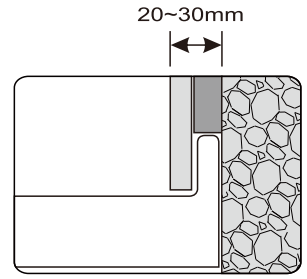

ATTENTION !
Attendre 24h avant d'installer votre porte de douche, afin de permettre au mortier et à la finition de sécher complètement.

WARNING !
Wait 24h before proceeding with the installation of the shower door. This will ensure that the finish and mortar is dry.

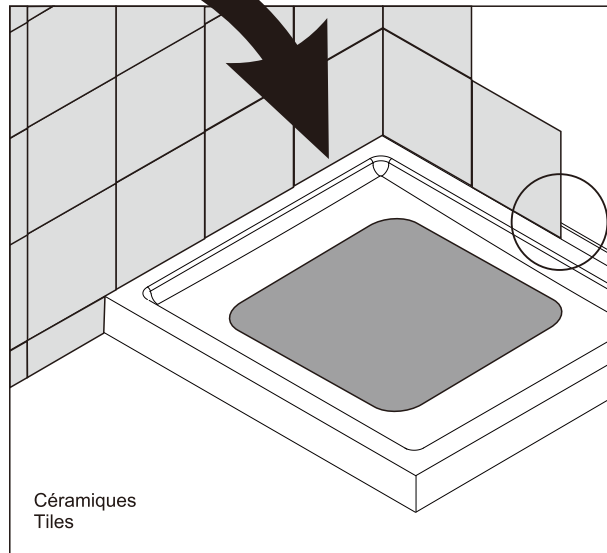

INSTALLATION EXTRUSION MURALE / WALL JAMB INSTALLATION

A 02

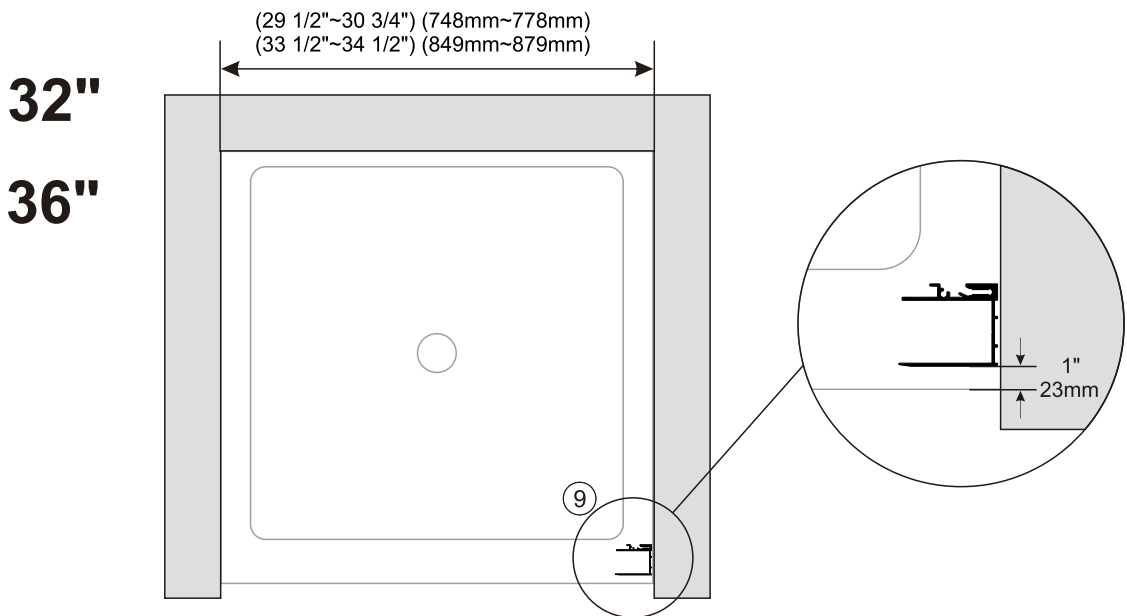

Inverser les étapes pour l'installation du pivot à gauche
Reverse the steps for to install the pivot on the left side.

SUITE / CONTINUED

A 03

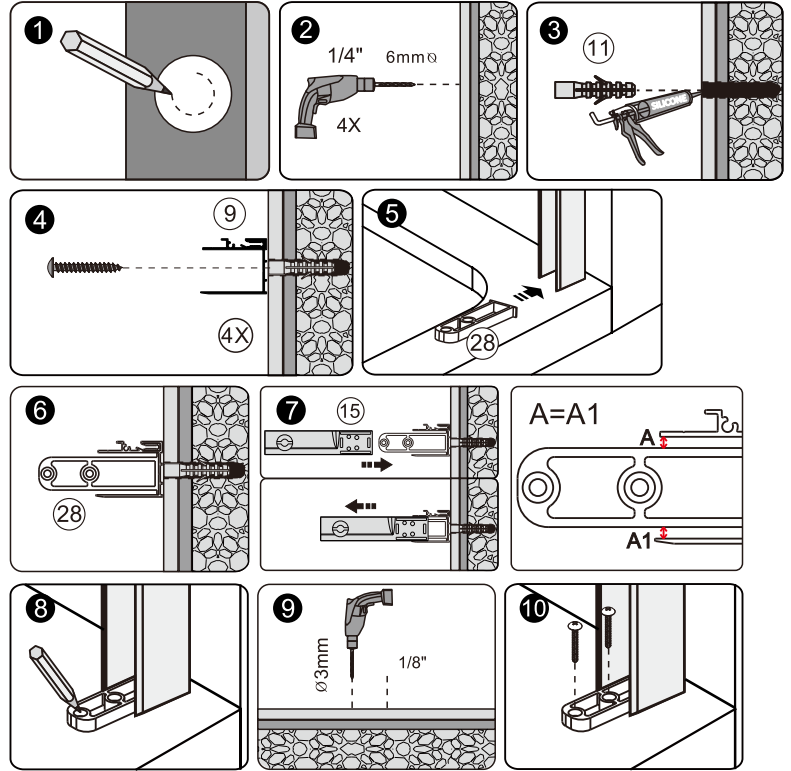
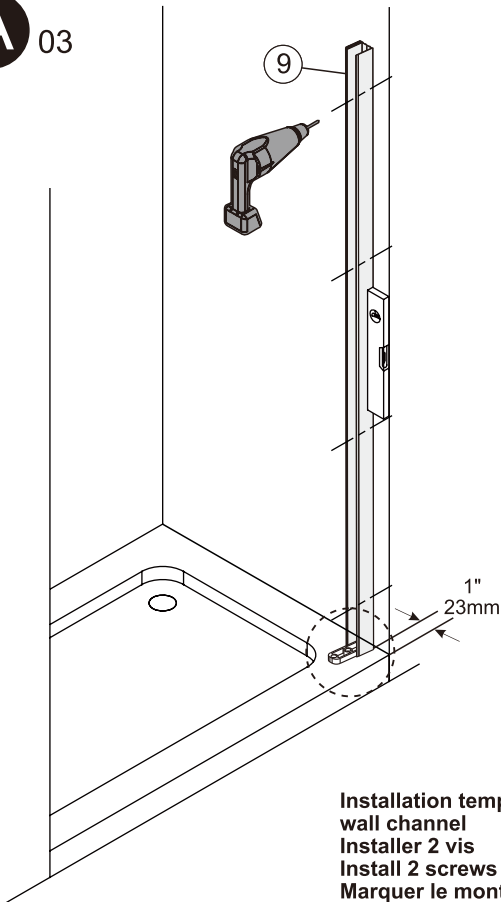

Installation temporaire du montant mural / temporary installation
 wall channel
 Installer 2 vis
 Install 2 screws
 Marquer le montant mural de chaque cotés
 Mark the wall channel on both side

SUITE / CONTINUED

A 04

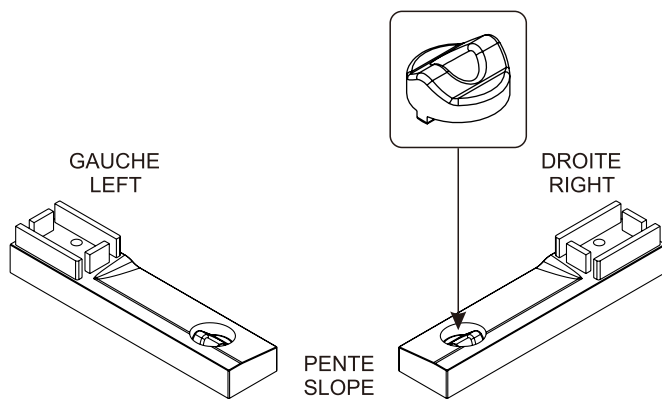

Important
 Choisir l'ancrage avec la pente vers l'intérieur pour installer en bas
 Select the bracket with the slope inward to settle down

Installer le bouton d'ouverture ascendant / descendant dans l'ancrage du bas
 Install the button lift up in the bottom bracket

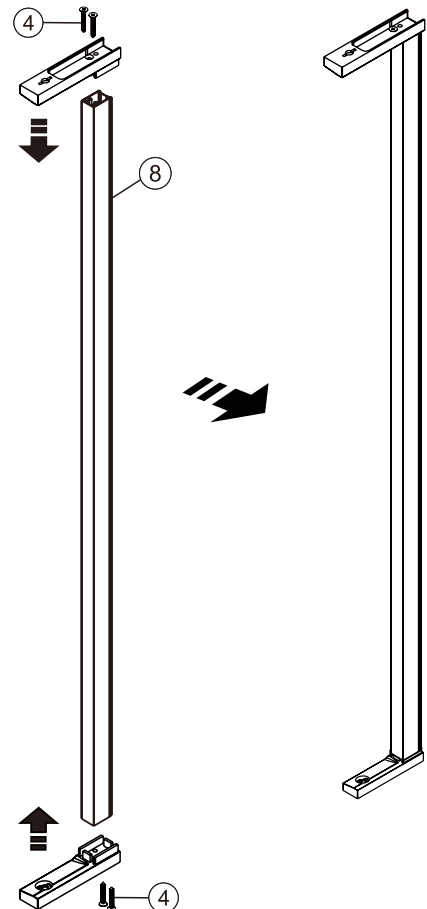

SUITE / CONTINUED

A 05

- 1 Insérer le montant du pivot 8 à l'intérieur du montant mural 9
Insert the pivot channel 8 within the wall channe 9
- 2 Insérer le support à pivot (ne pas visser) et marquer les trous
Insert the pivot support (do not screw) and mark the holes
- 3 Enlever le montant du pivot 8 et le montant mural 9 pour percer les trous
Remove the pivot channel 8 and wall channel 9 to drill the holes
- 4 Réinstaller le montant mural no9 et insérer le montant du pivot no8
reinstall the wall channel no9 and insert the pivot channel no8

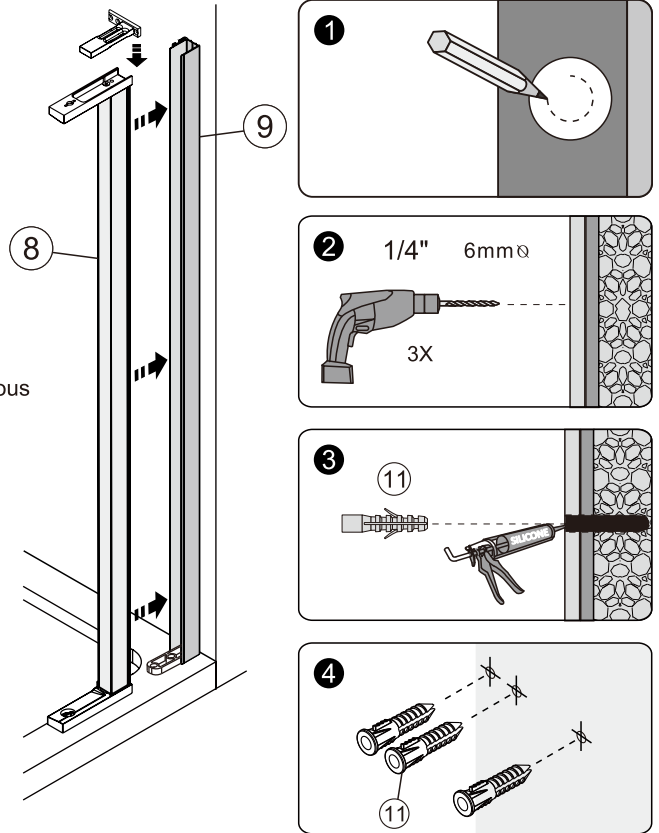

Préparation de la porte / Doorpreparation

A 06

Installation en bas ou en haut
Install top or bottom

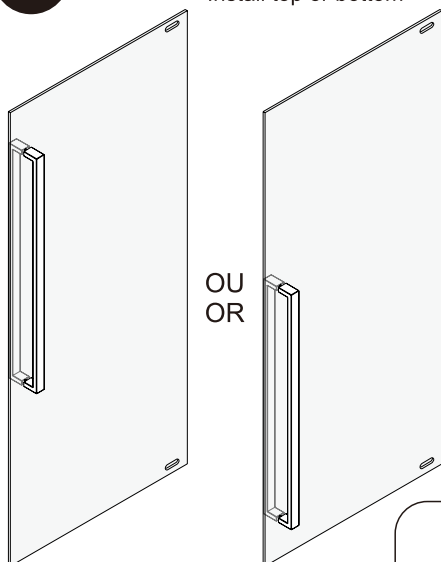

- 1 Enlever les caps et les vis sur les deux pivots
Remove the caps and the screws on the two pivots
- 2 Choisir le positionnement de la poignée no 20
Choose the positioning of the handle no 20
- 3 Installer les pivots et la poignée
Install the pivots and the handle

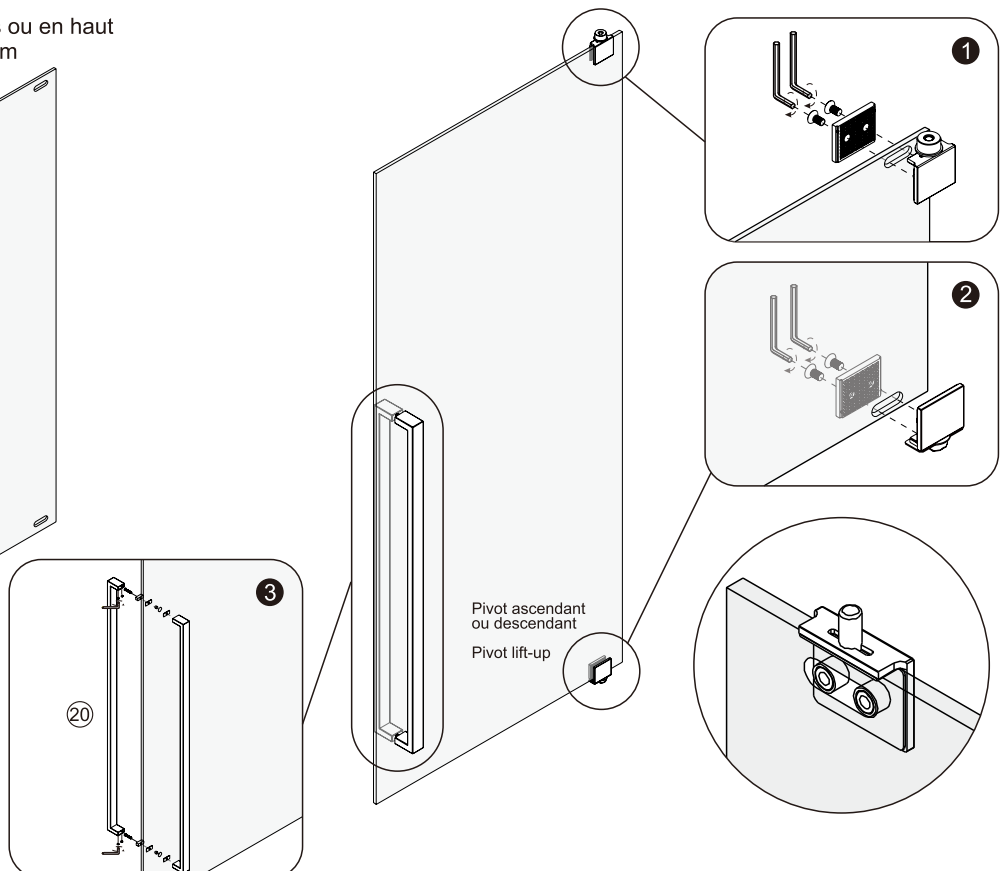

A 07

Étape difficile de l'installation recommandons 2 personnes
 Difficult step of the installation, we strongly recommend 2 persons

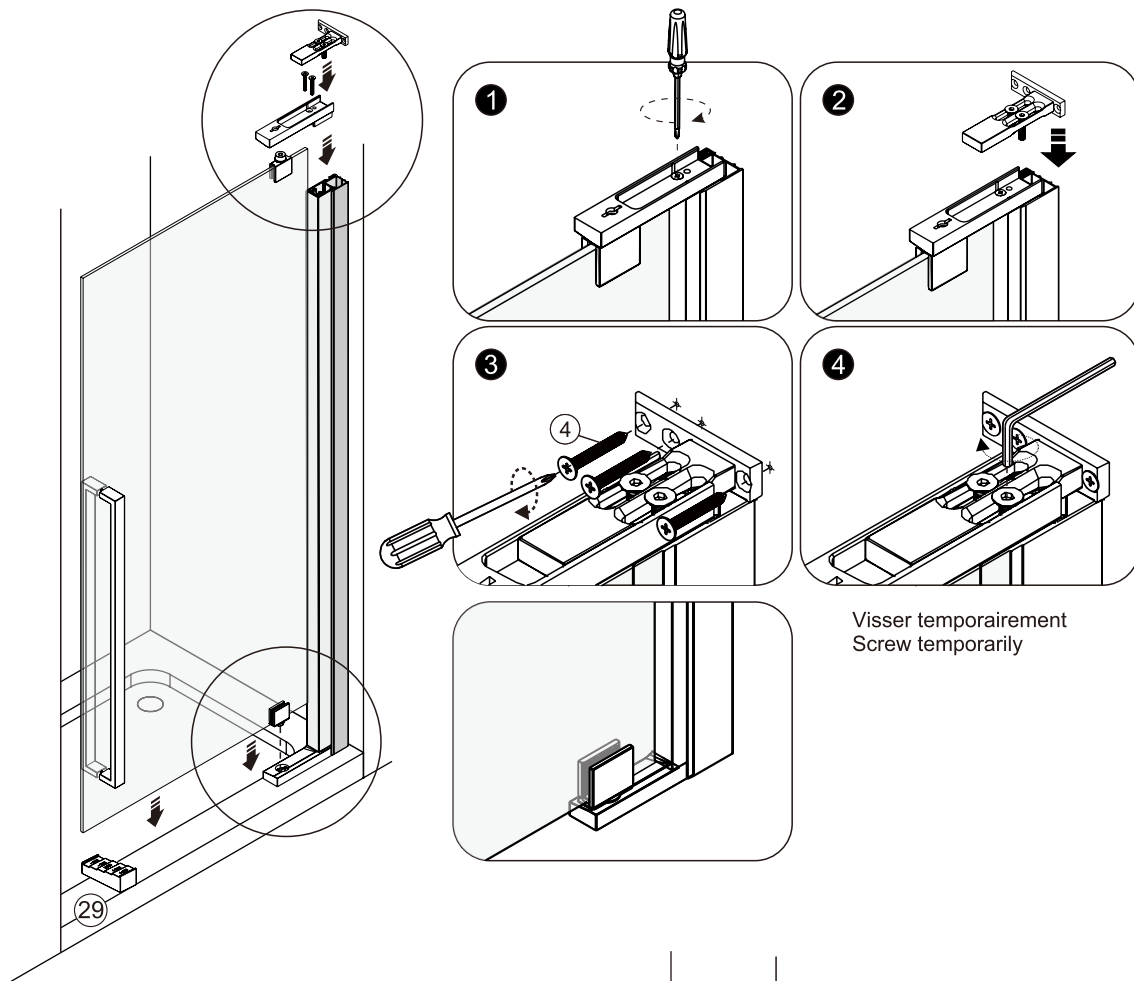

Visser temporairement
 Screw temporarily

Enlever l'ancrage du pivot de haut
 Remove upper bracket pivot

- 1 Insérer la porte
 Insert the door
- 2 Visser l'ancrage du pivot du haut
 Screw upper bracket pivot
- 3 Visser le support du pivot au mur et sur l'ancrage du pivot
 Screw the pivot bracket to the wall and anchor the pivot

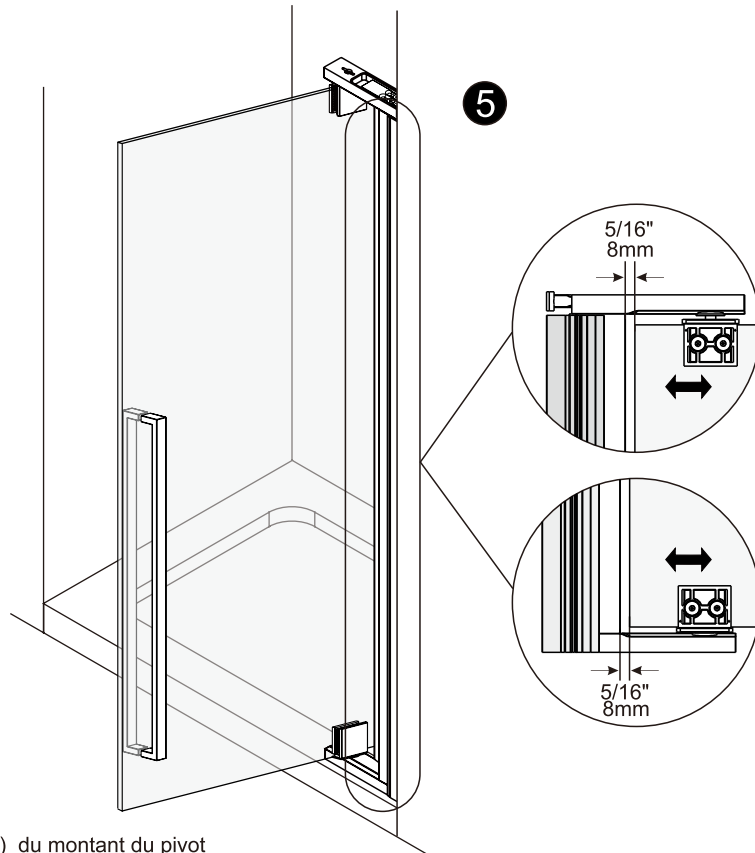

- 5 Devisser un peu les pivots pour ajuster la porte à 5/16"(8mm) du montant du pivot
 Unscrew slightly pivots to adjust the door 5/16"(8mm) of the amount of pivot

SUITE / CONTINUED

A 08

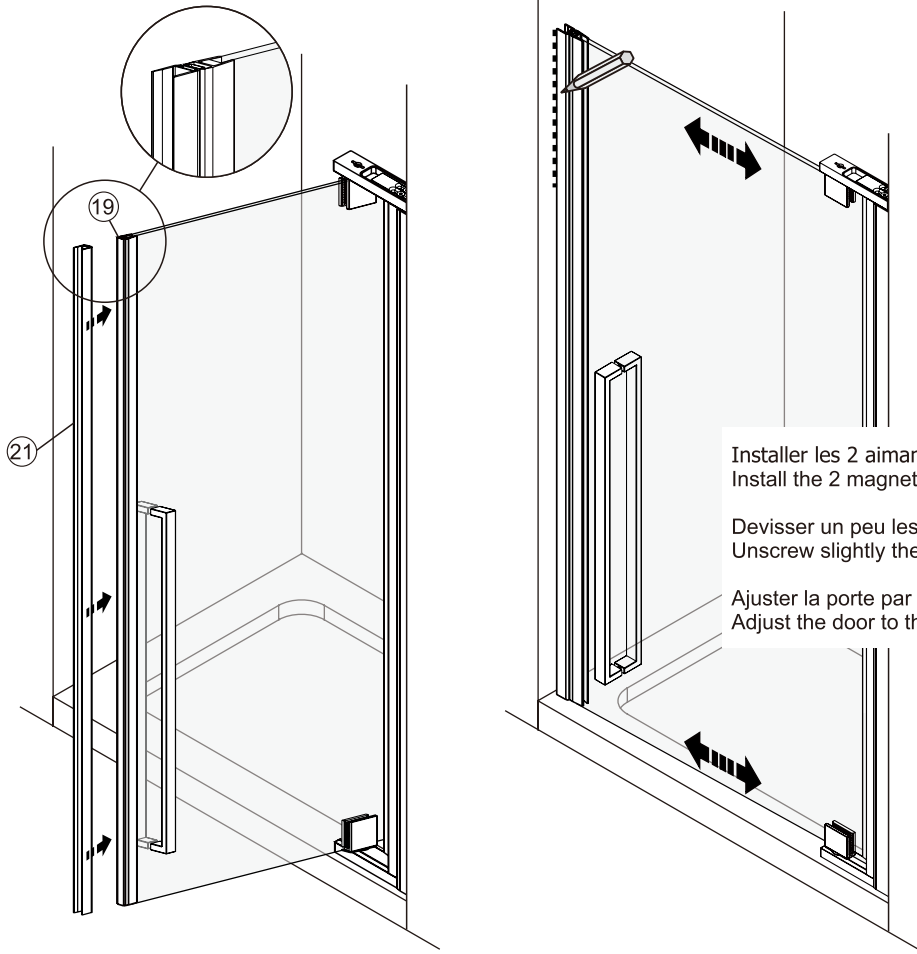

Installer les 2 aimants No19 et 21
Install the 2 magnets No19 et 22

Devisser un peu les vis de la bracket du pivot
Unscrew slightly the screws of the pivot bracket

Ajuster la porte par rapport au mur et marquer
Adjust the door to the wall and mark

SUITE / CONTINUED

A 09

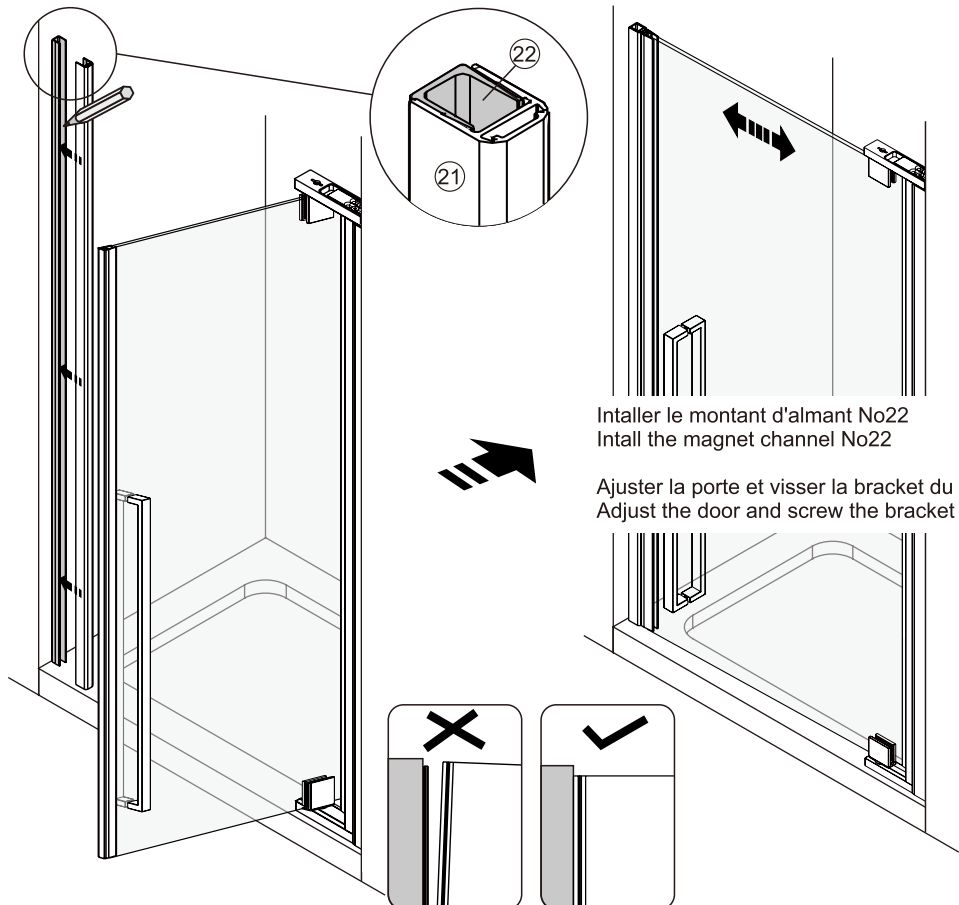
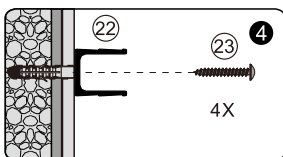
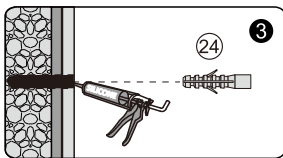
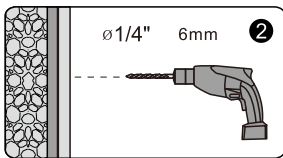
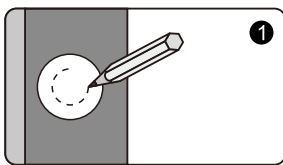

Intaller le montant d'aimant No22
Intall the magnet channel No22

Ajuster la porte et visser la bracket du pivot
Adjust the door and screw the bracket pivot

SUITE / CONTINUED

A 10

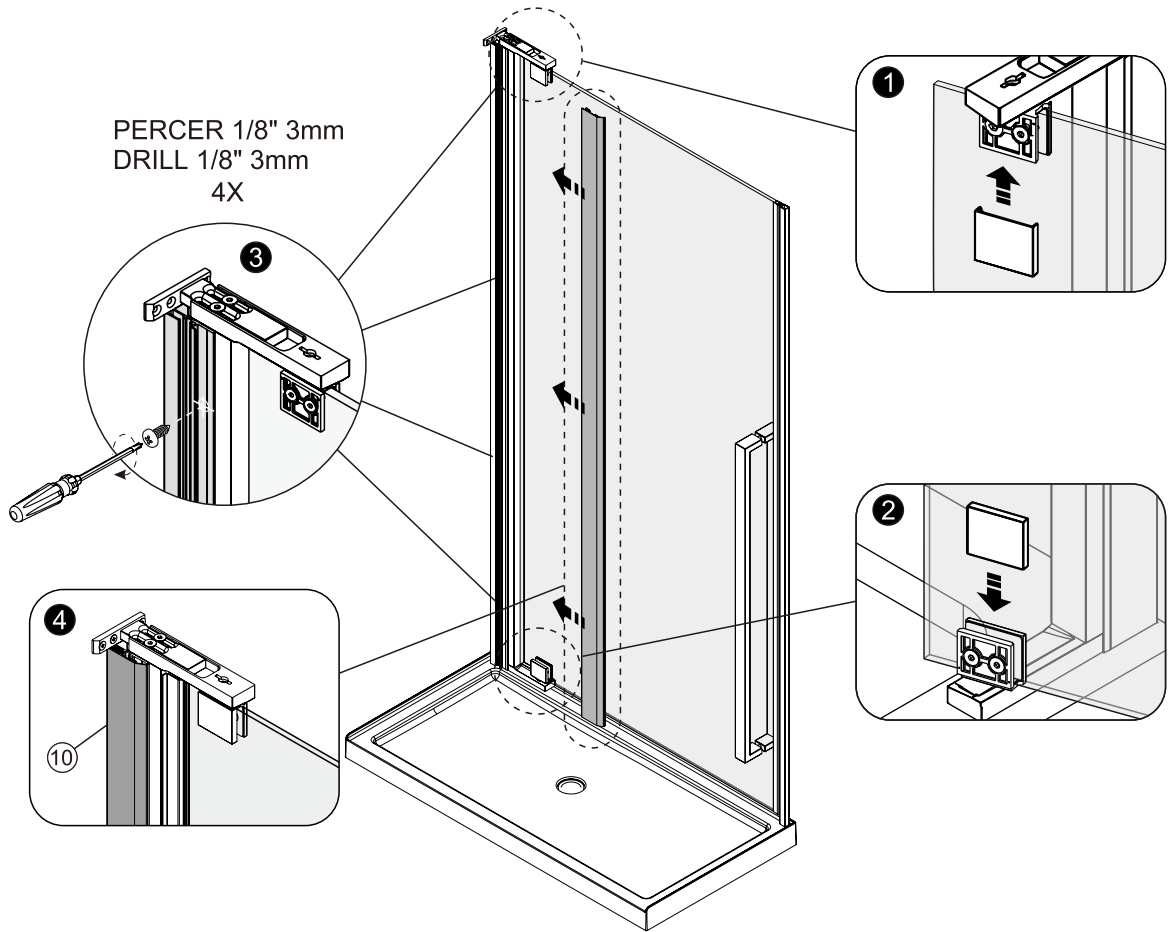

SUITE / CONTINUED

A 11

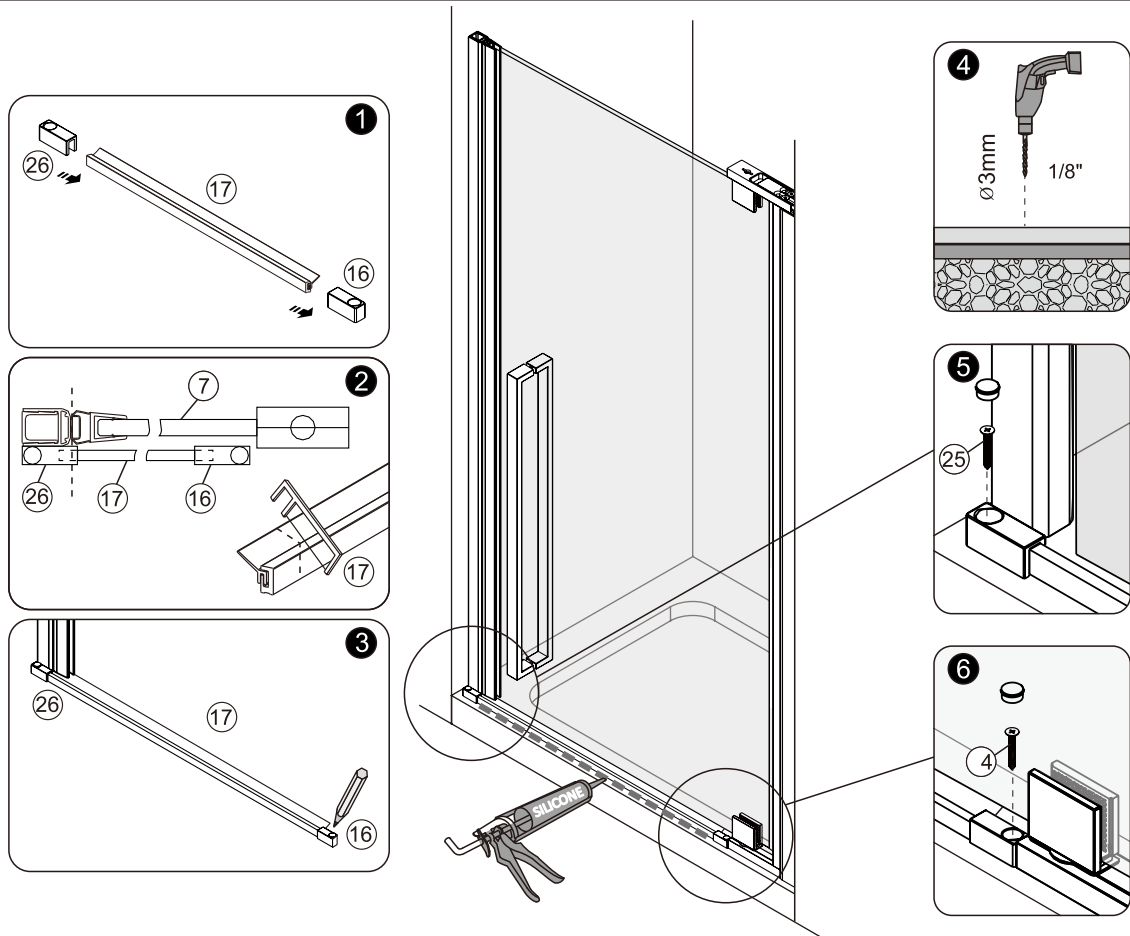

SUITE / CONTINUED

A 12

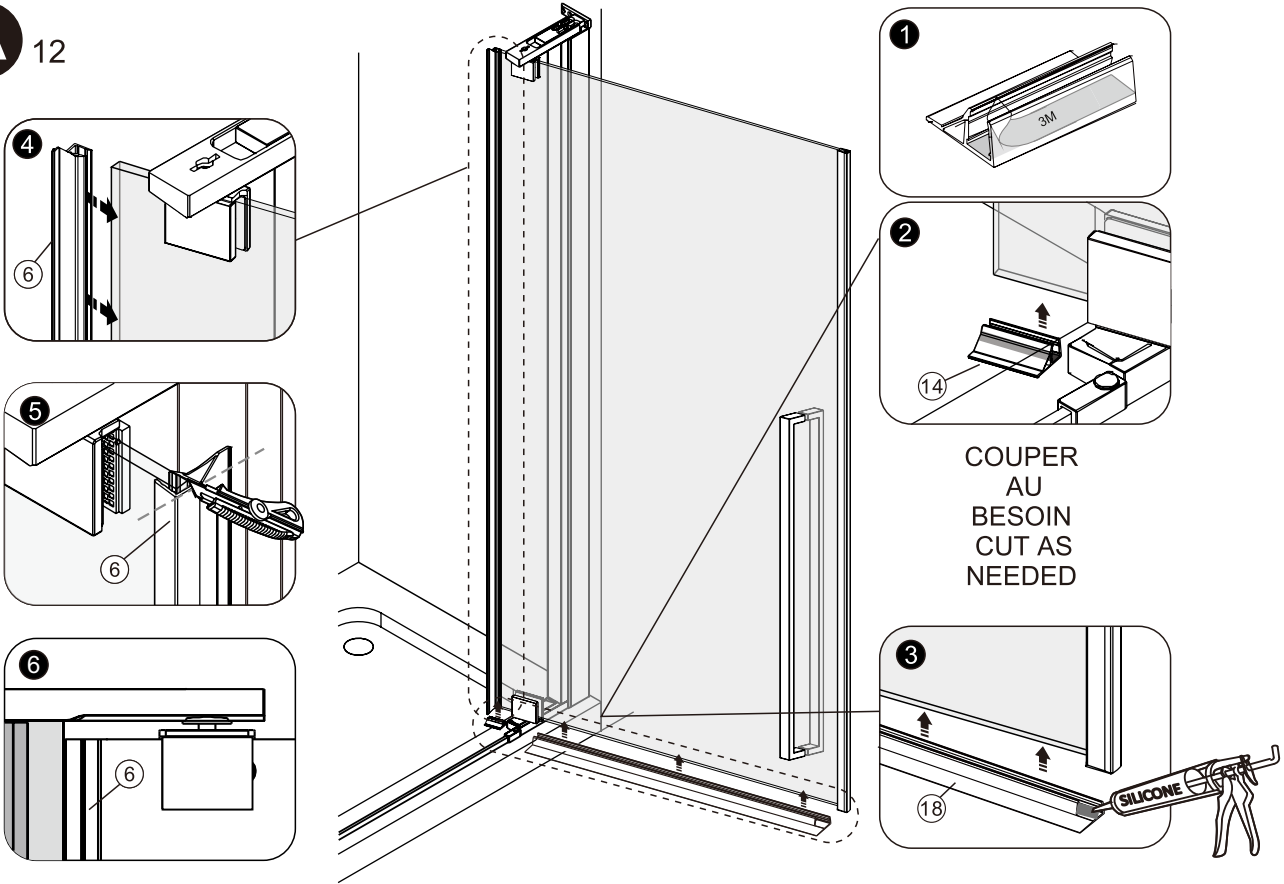

SUITE / CONTINUED

A 13

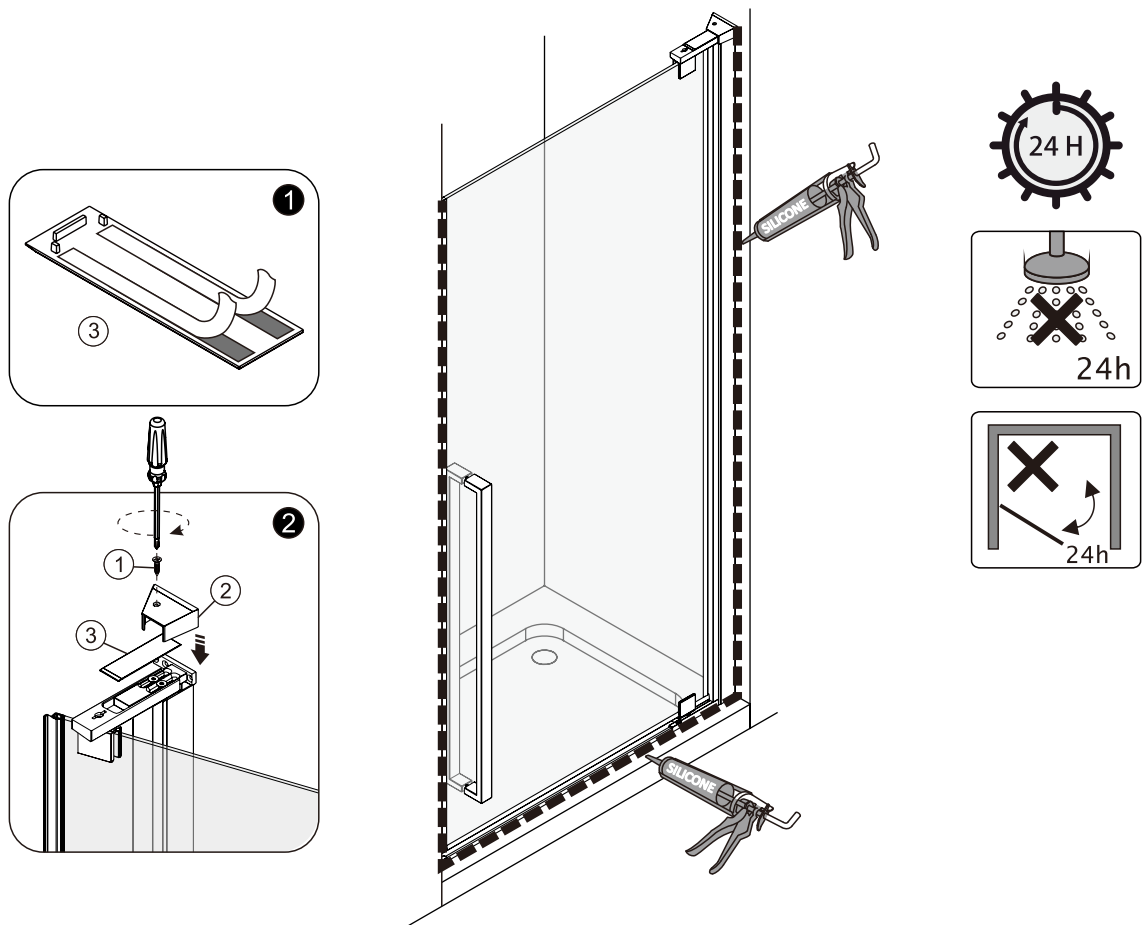

INSTALLATION EXTRUSION MURALE / WALL JAMB INSTALLATION

B 01

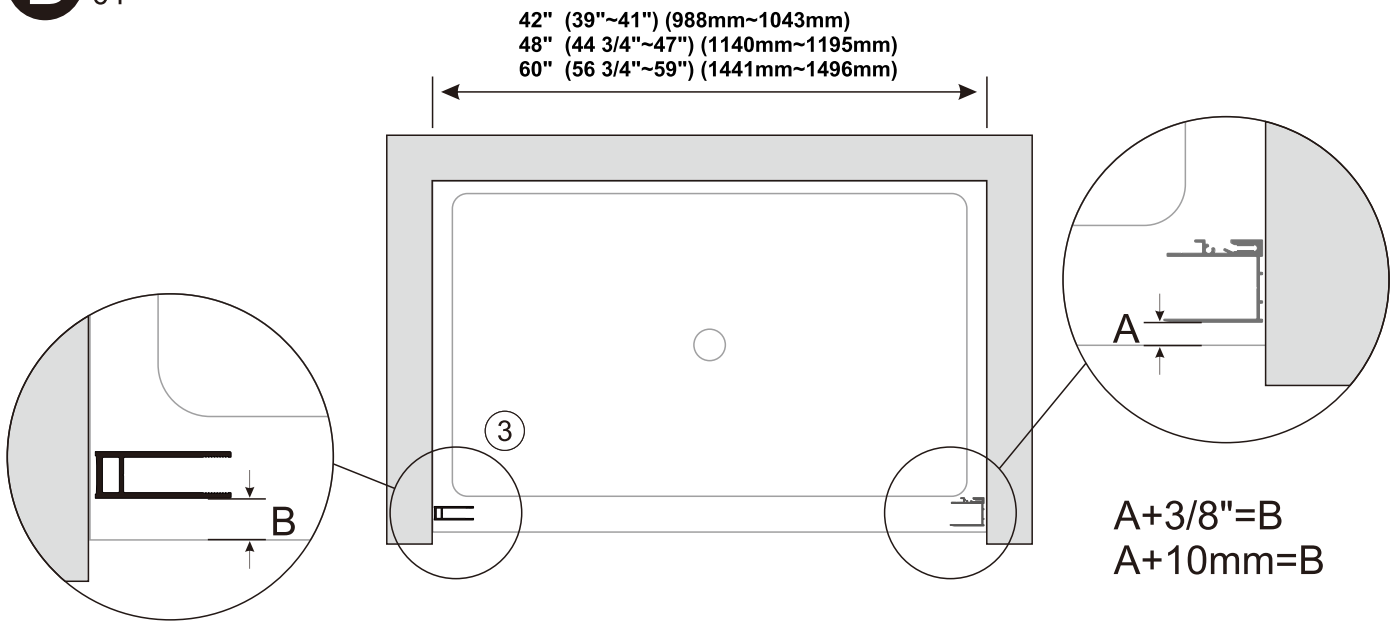

Inverser les étapes pour la porte coulissante à gauche
 Reverse the steps for the sliding door on the left

SUITE / CONTINUED

B 02

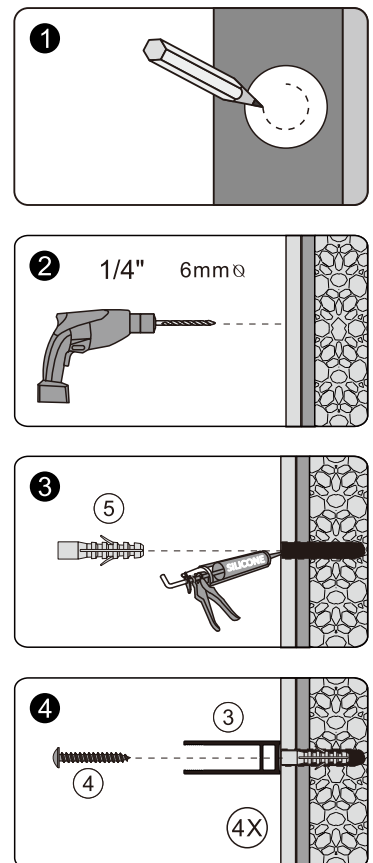
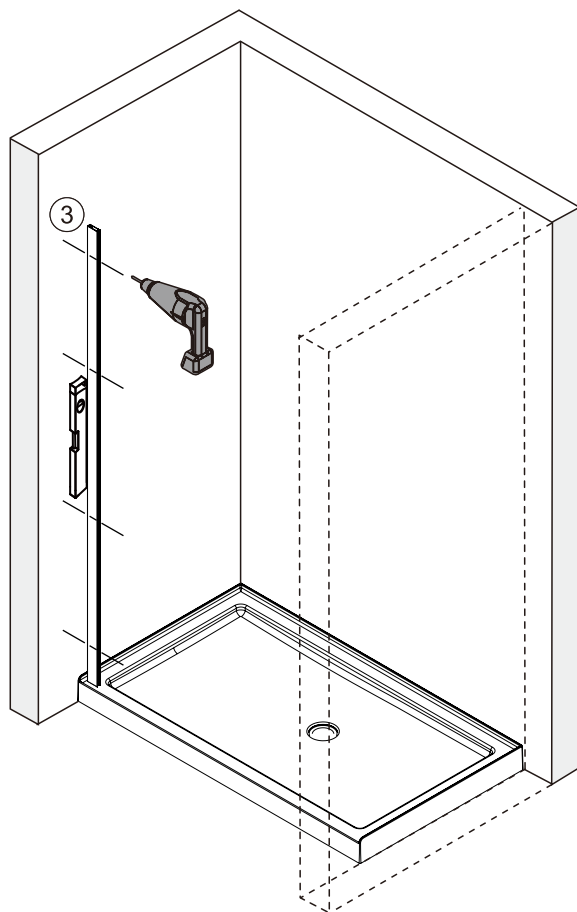

SUITE / CONTINUED

B 03

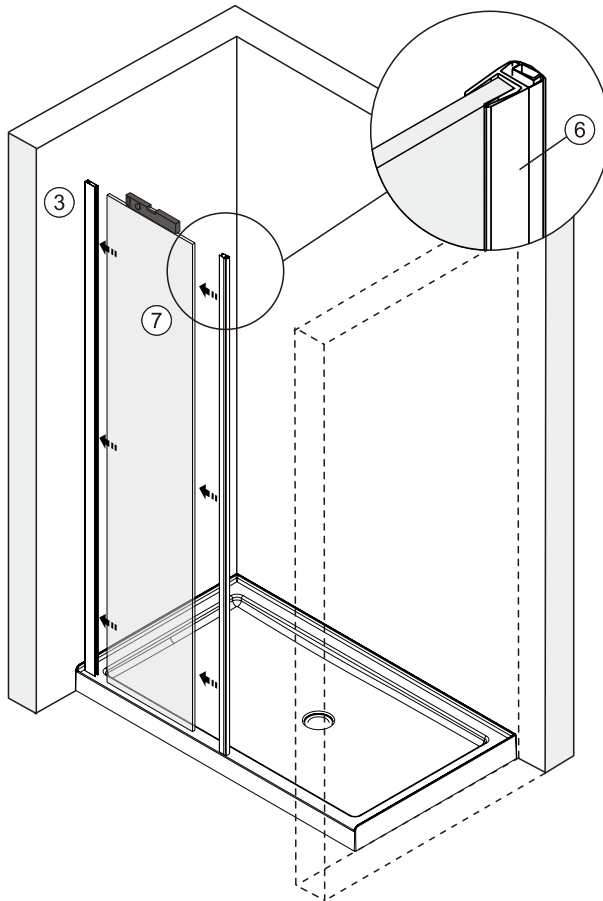

Minimum 3/8" (10mm)

Commencez par le bas
Start at the bottom

interieur
Inside

3

7

Insérer partiellement le joint de serrage.
ajuster et serrer seulement à la fin de
l'installation de la porte.

Partially insert gasket, adjust & tighten
at the end of door installation.

SUITE / CONTINUED

B 04

PERCER 1/8" 3mm
DRILL 1/8" 3mm
4X

1

2

3

4

10

X

✓

SUITE / CONTINUED

B 05

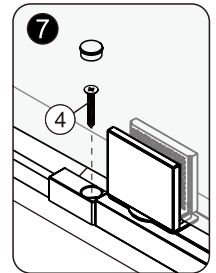
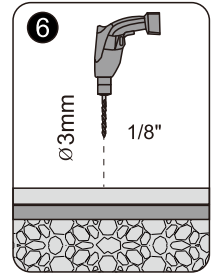
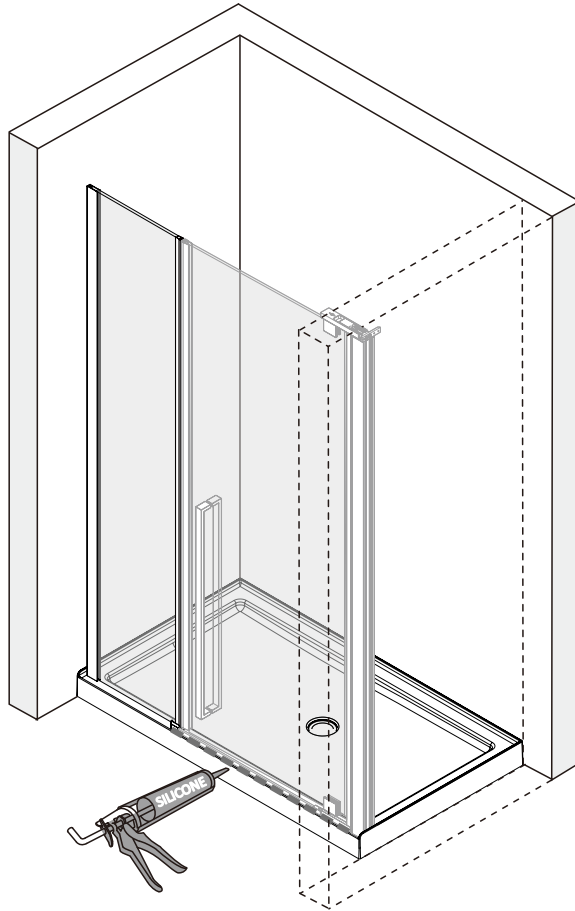
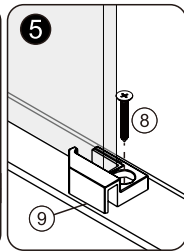
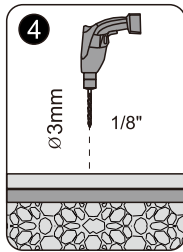
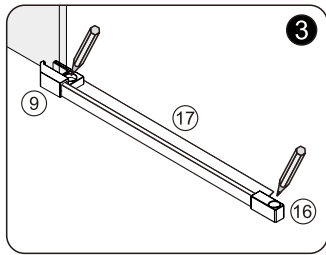
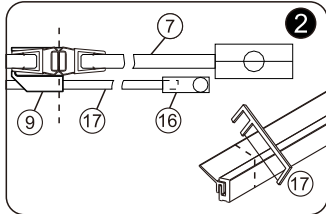
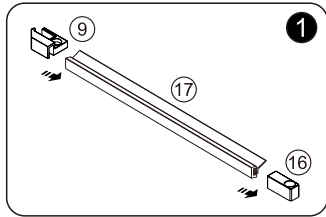

SUITE / CONTINUED

B 06

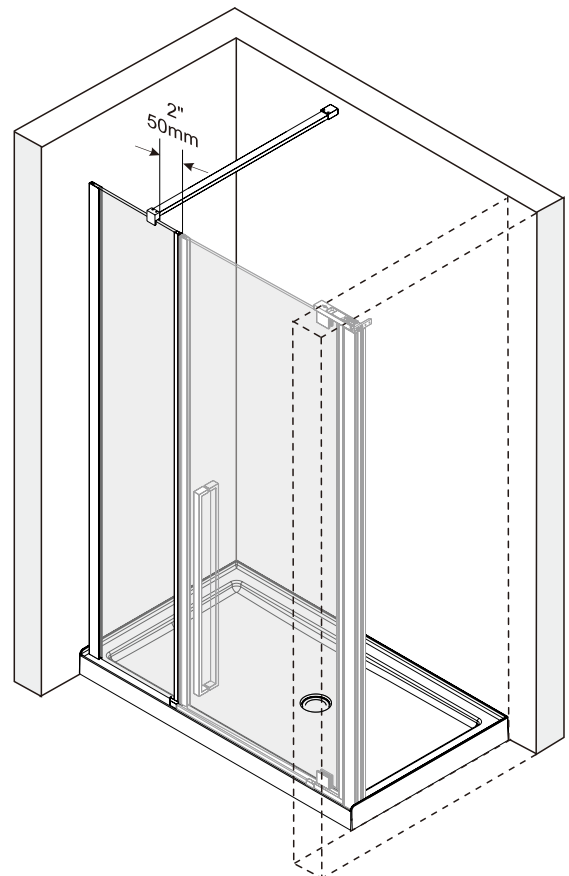
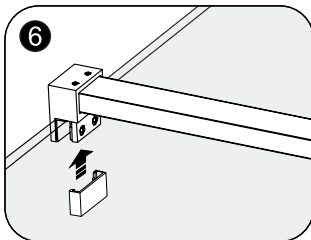
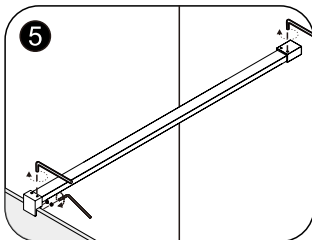
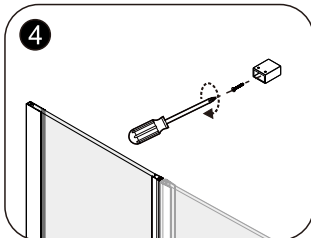
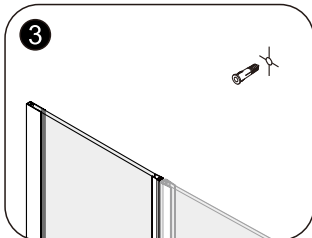
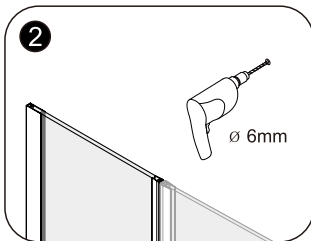
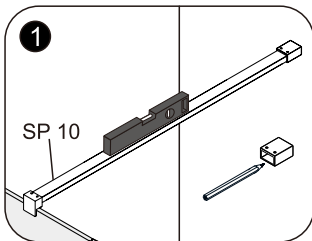

SUITE / CONTINUED

B 07

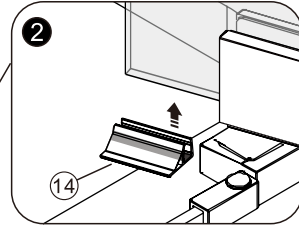
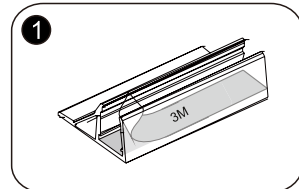
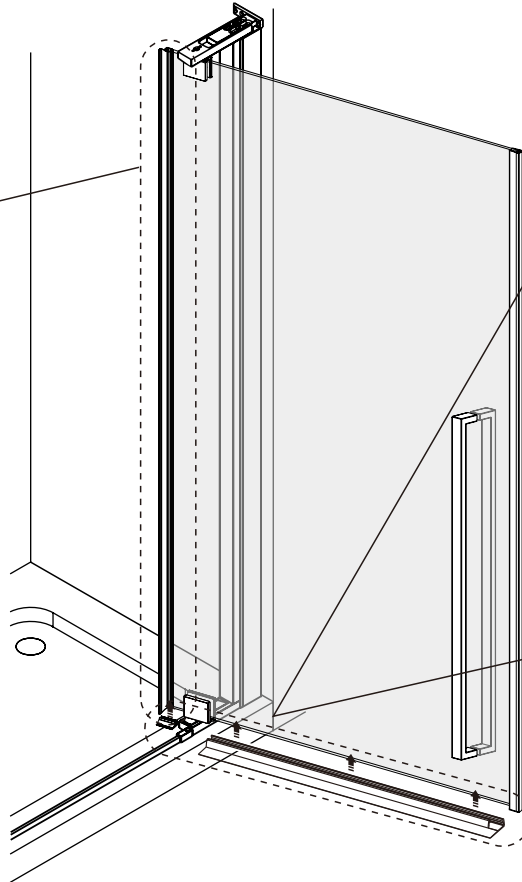
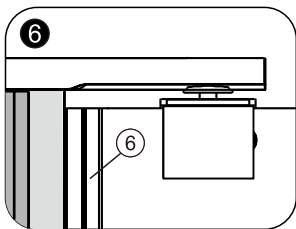
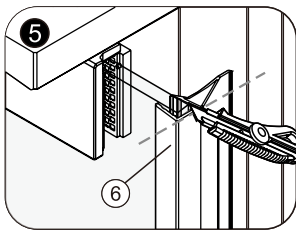
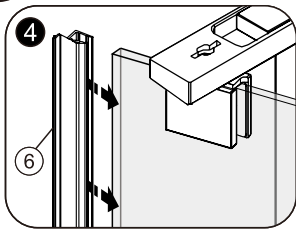

COUPER
AU
BESOIN
CUT AS
NEEDED

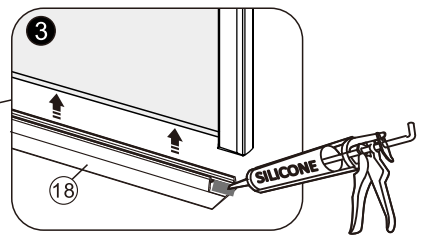

SUITE / CONTINUED

B 08

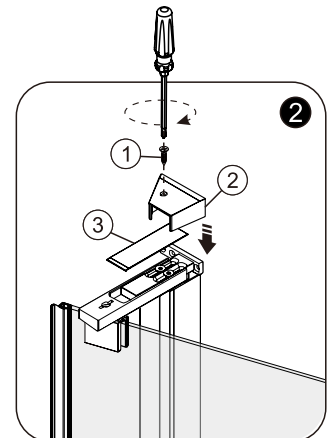
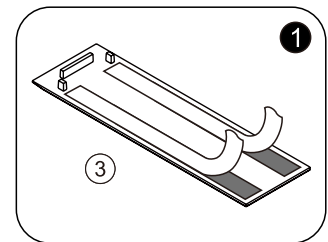
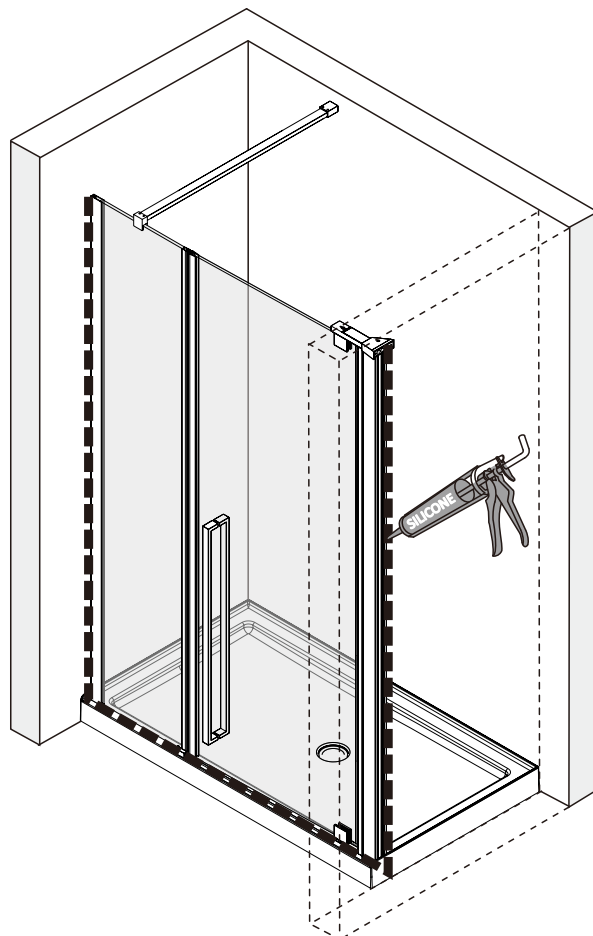
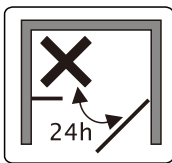
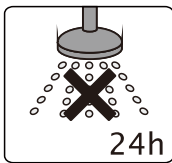

SUITE / CONTINUED

C 01

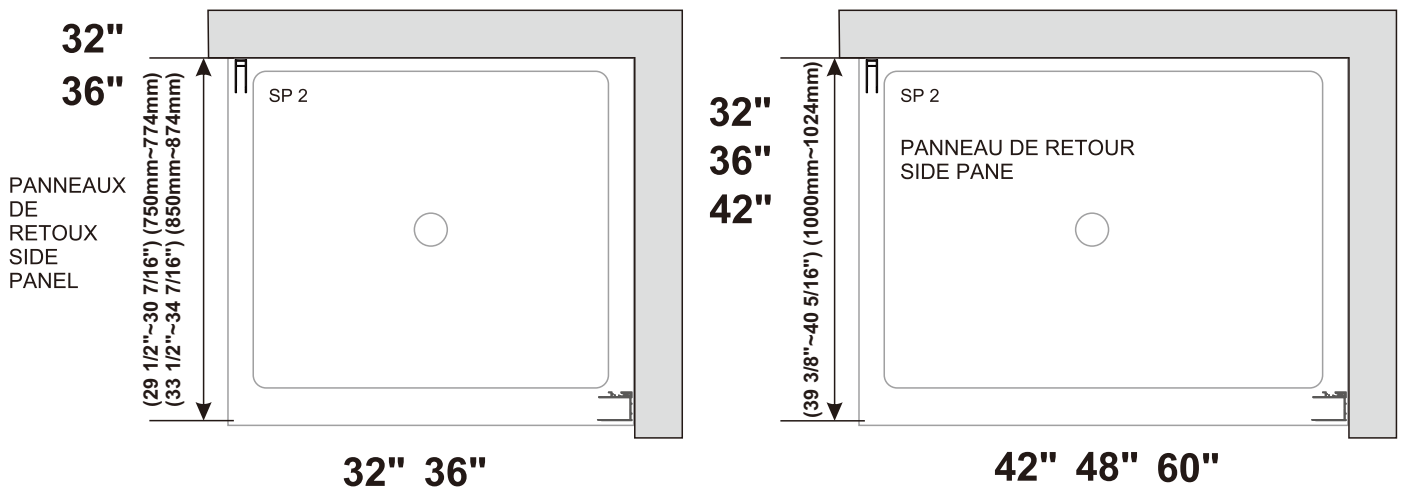

Inverser les étapes pour la porte coulissante à gauche
 Reverse the steps for the sliding door on the left

SUITE / CONTINUED

C 02

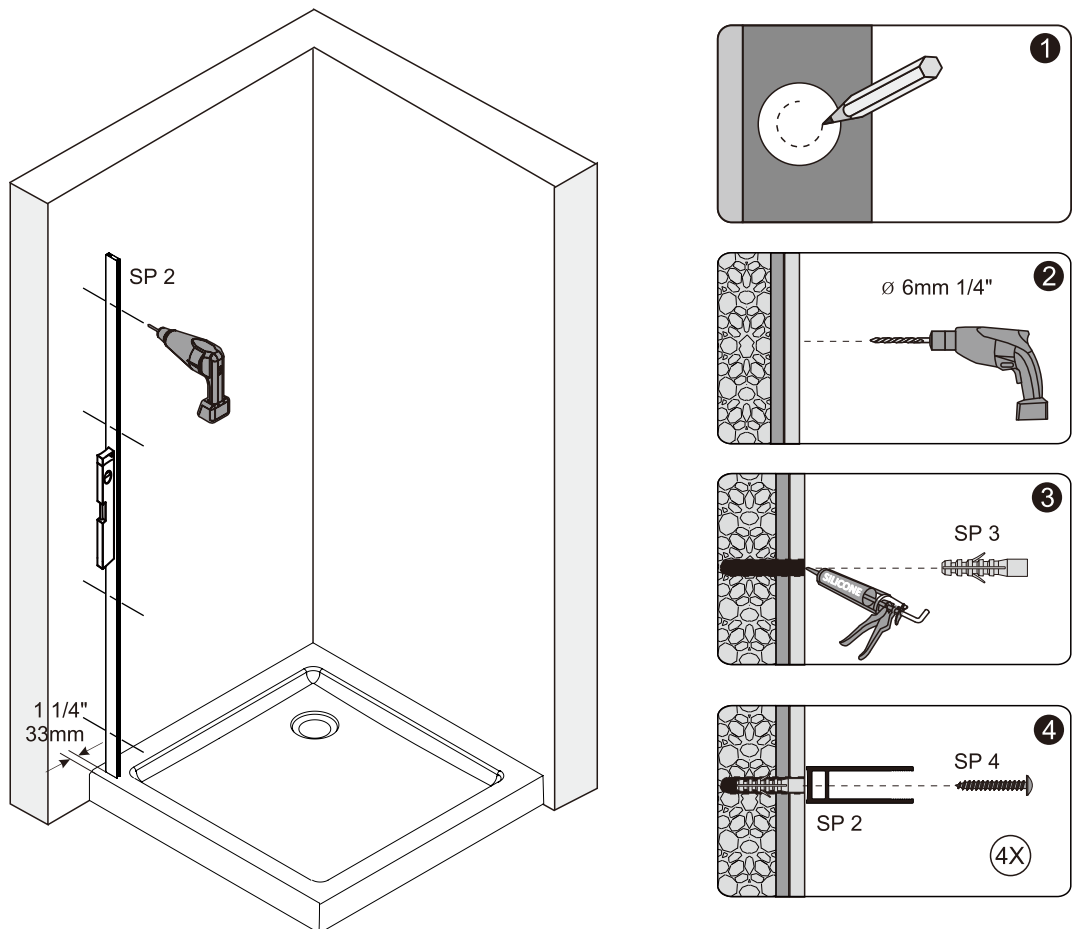

SUITE / CONTINUED

C 03

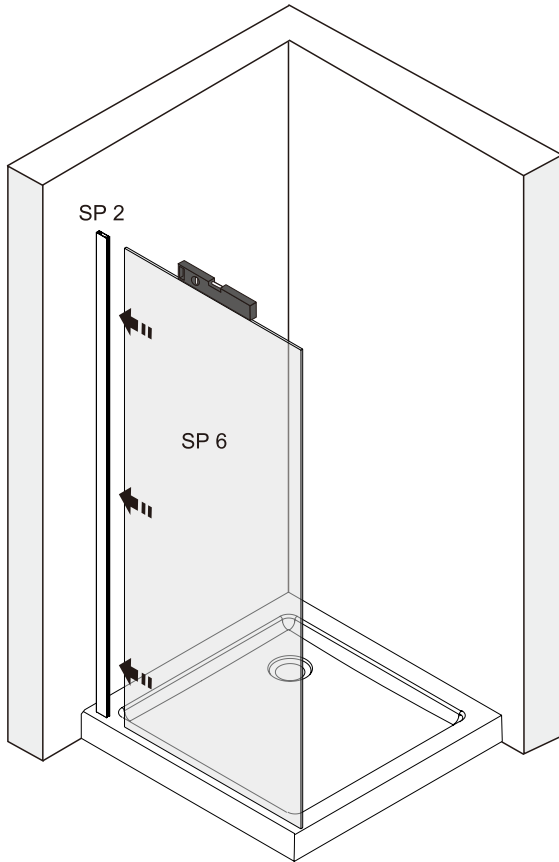

Minimum 3/8" (10mm)

Commencez par le bas
Start at the bottom

interieur
Inside

SP 5

SP 2

SP 10

SP 6

Insérer partiellement le joint de serrage.
ajuster et serrer seulement à la fin de
l'installation de la porte.

Partially insert gasket. adjust & tighten
at the end of door installation.

SUITE / CONTINUED

C 04

1

SP 9

2

∅3mm
1/8"

3

SP 8

SP 9

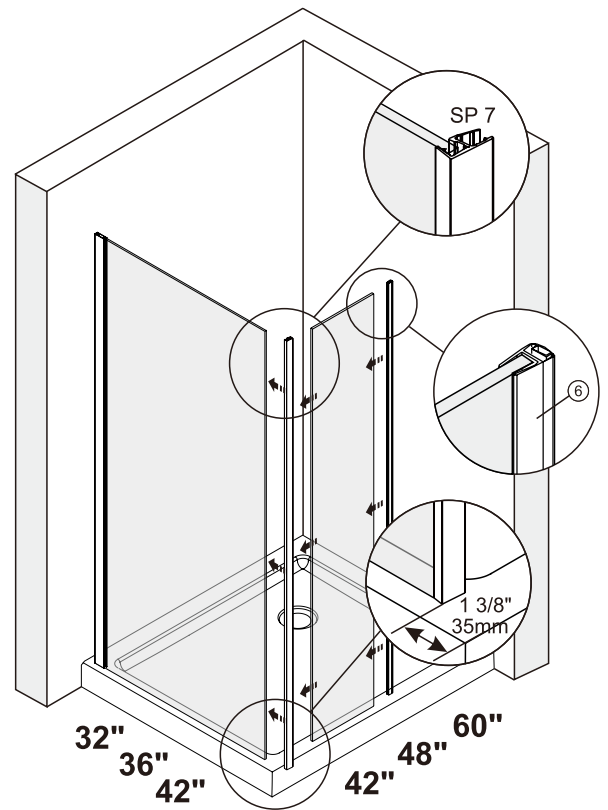
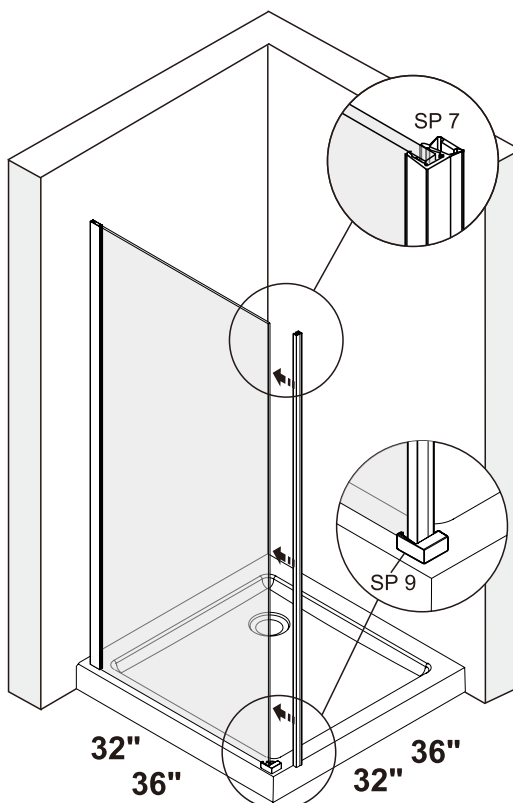

SUITE / CONTINUED

C 05

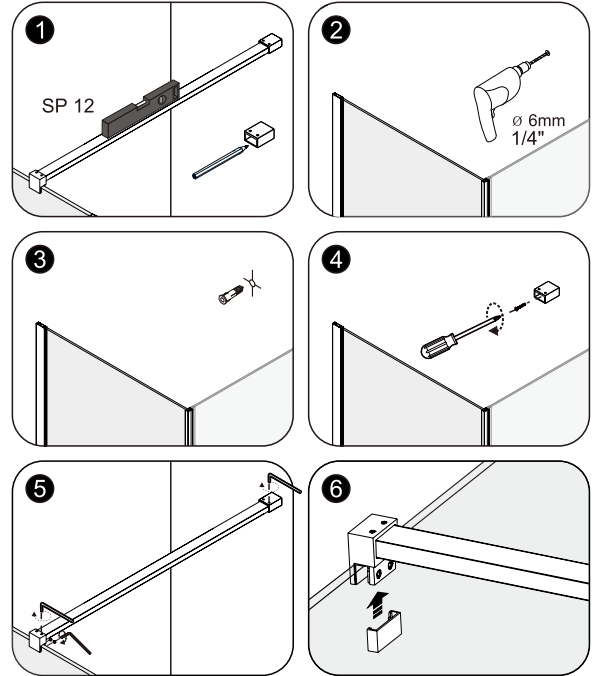
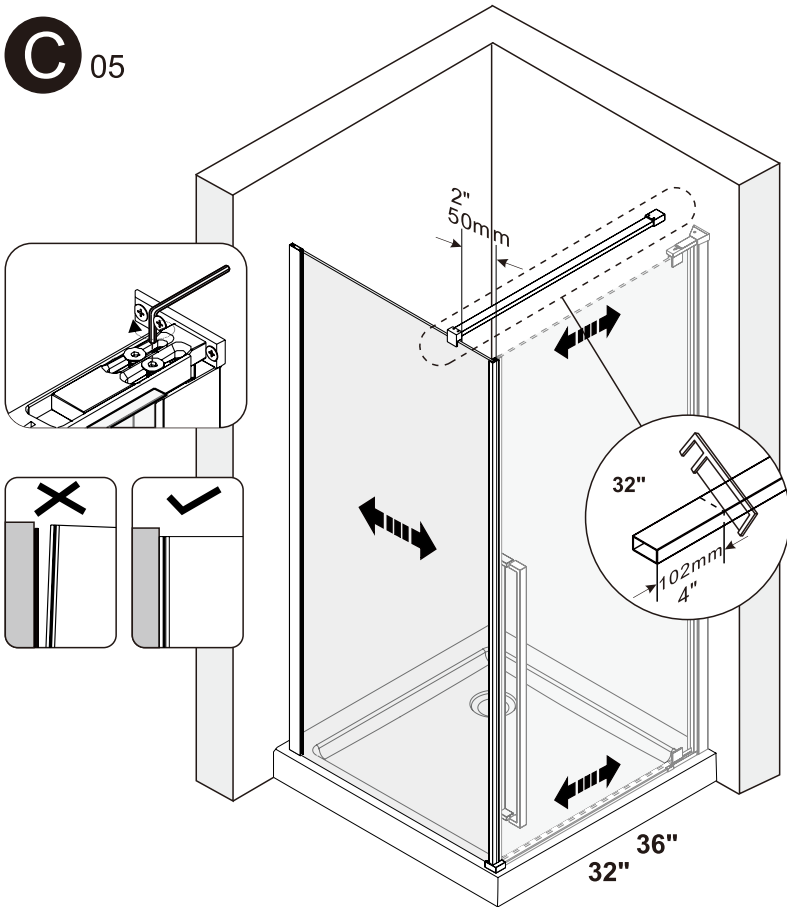

SUITE / CONTINUED

C 06

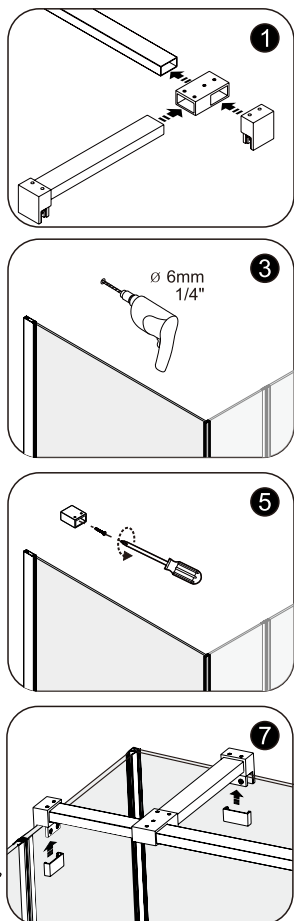
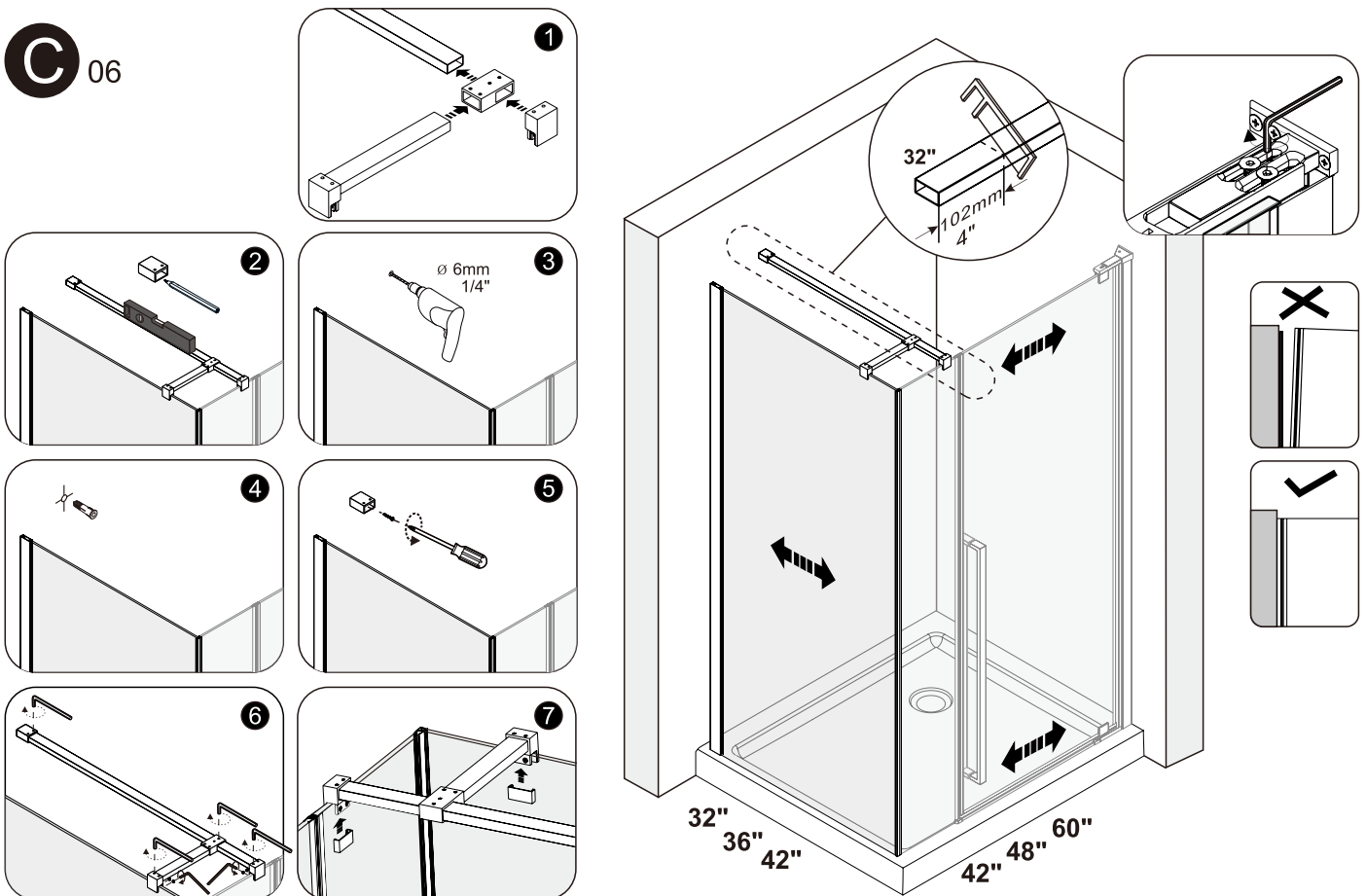

SUITE / CONTINUED

C 07

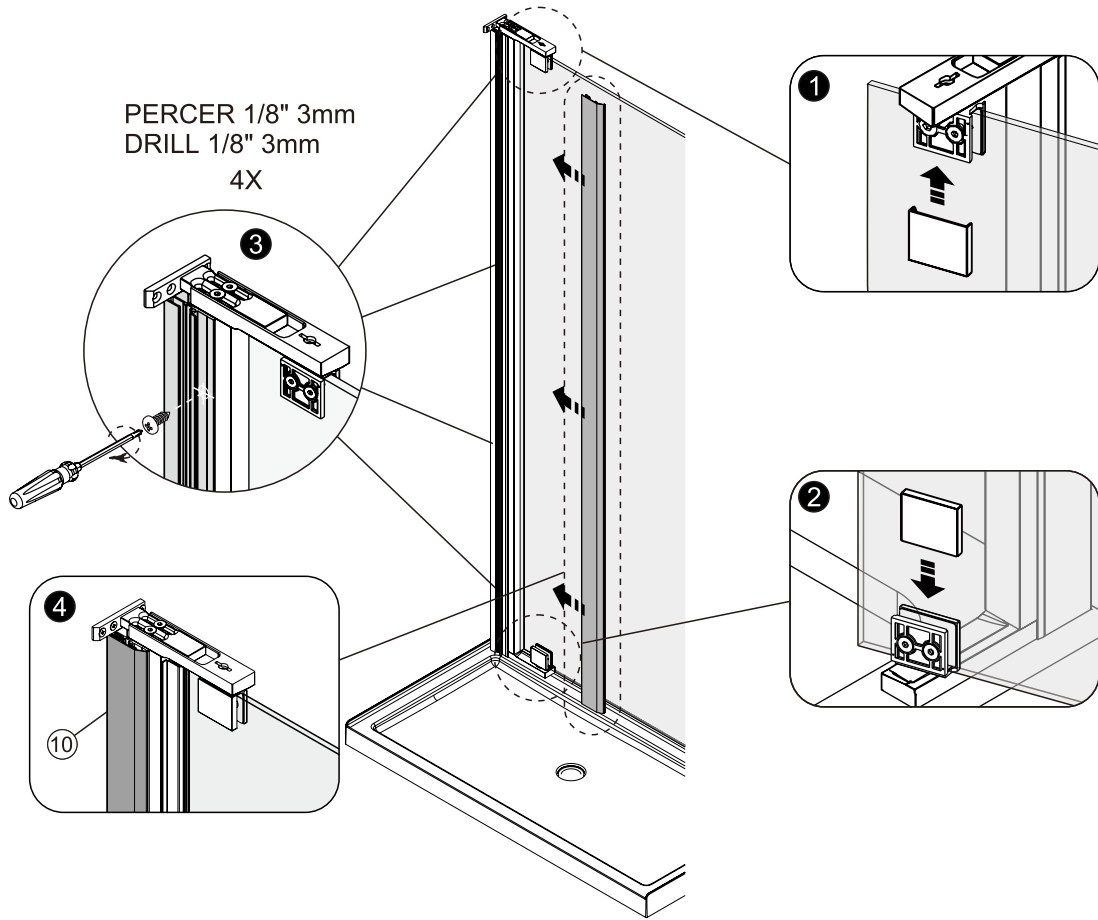

SUITE / CONTINUED

C 08

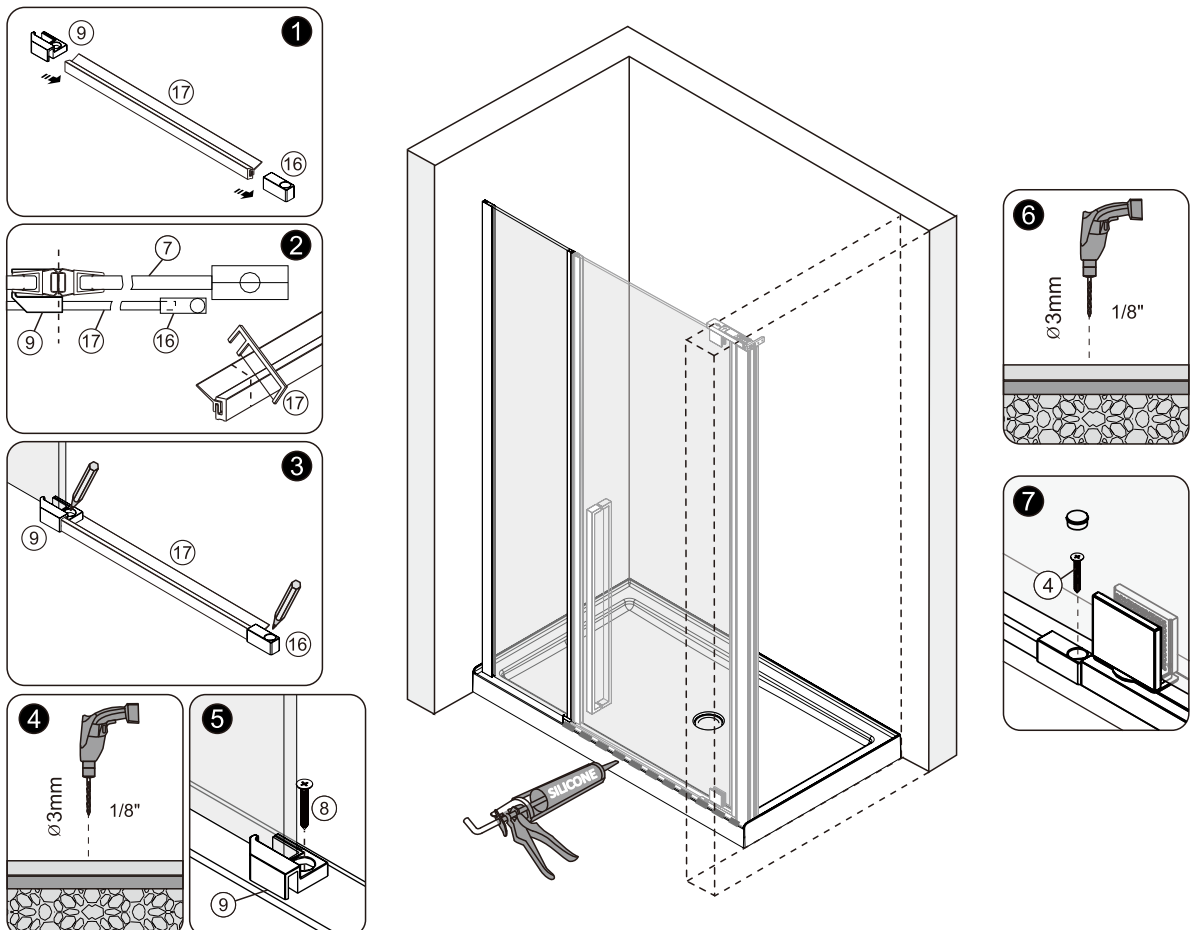

C 09

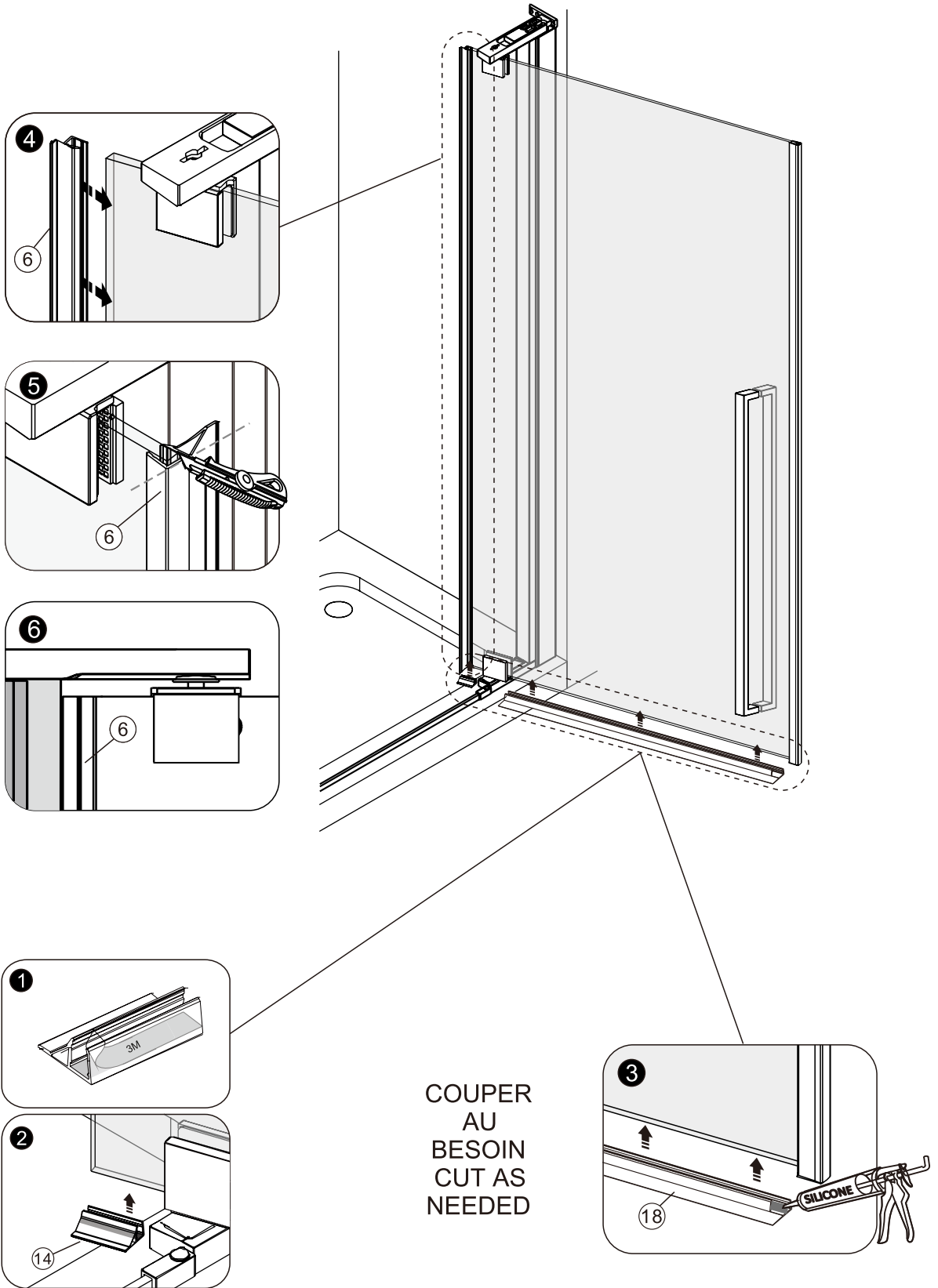

COUPER
AU
BESOIN
CUT AS
NEEDED

C 10

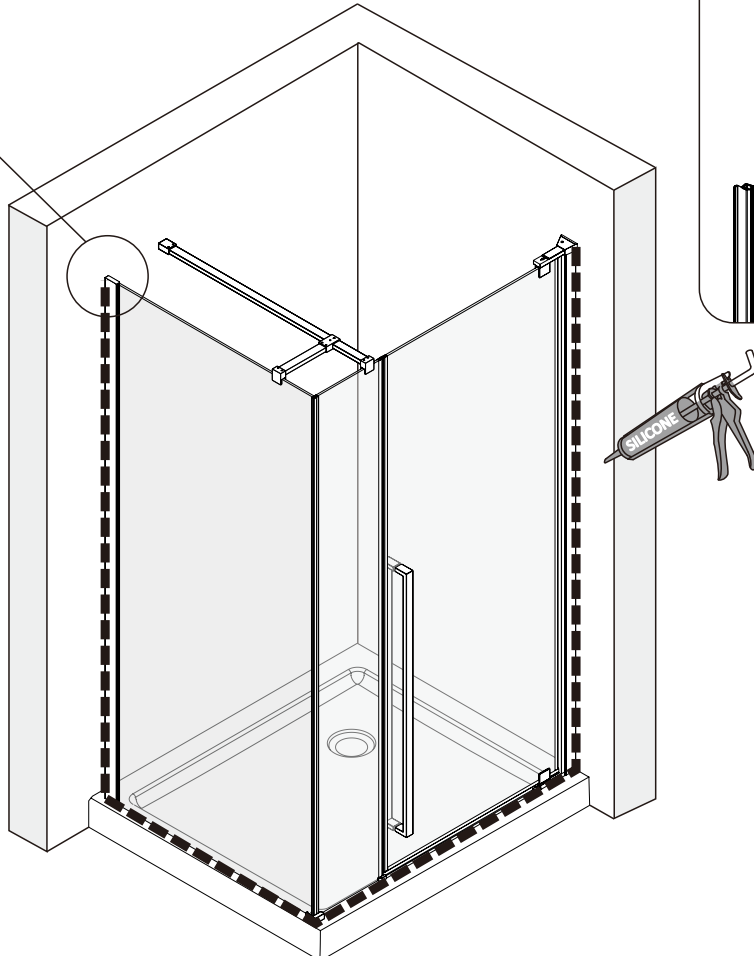
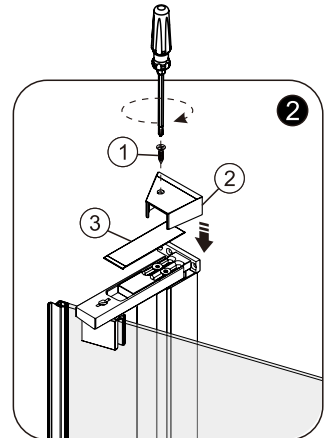
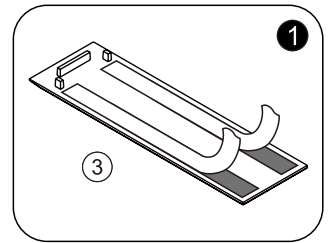
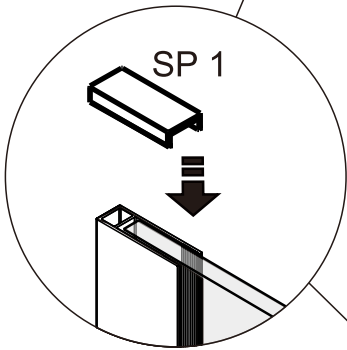
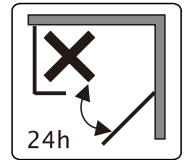
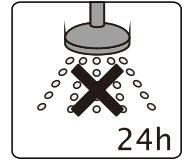
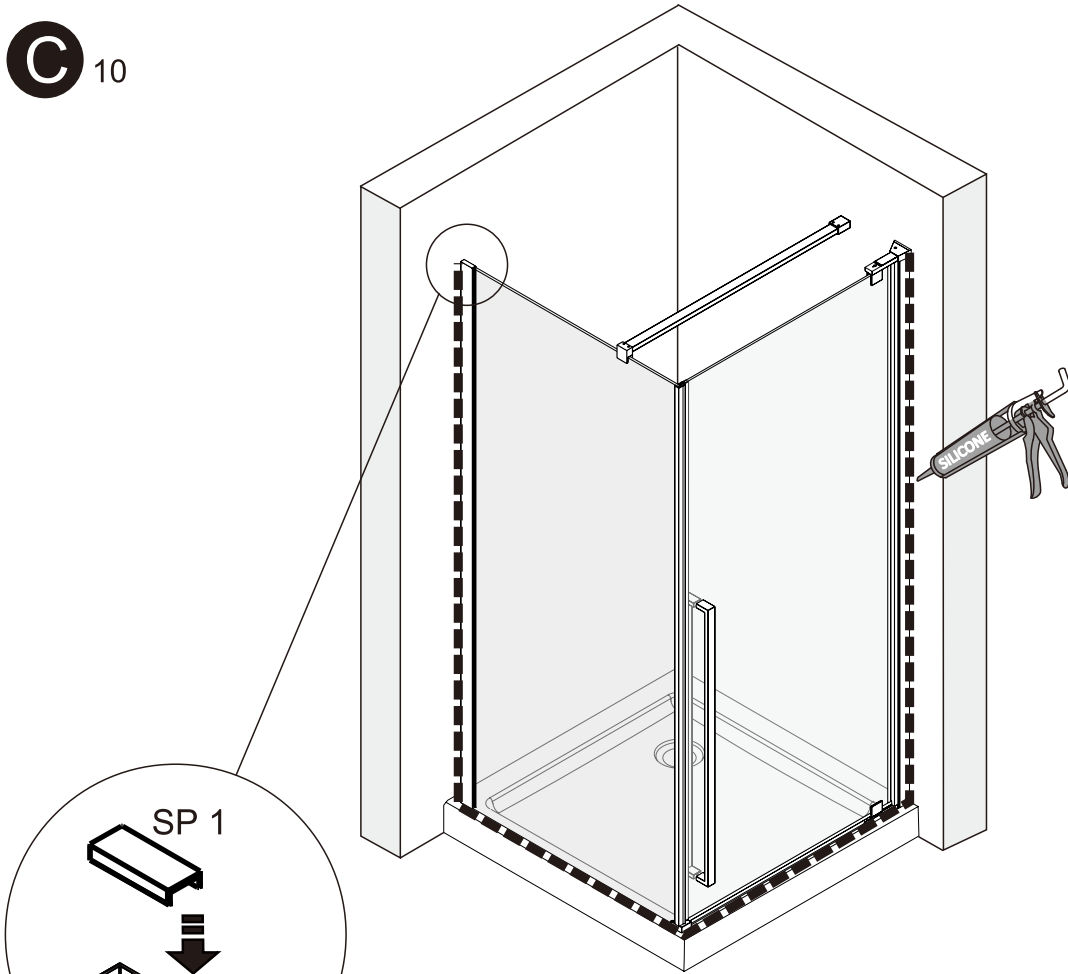

Garantie / Warranty

Garantie	Baignoire / Douche	Warranty	Bathtub / Shower
Acrylique	10 ans	Acrylic	10 years
Porte de Douche	5 ans	Shower Door	5 years
Roulette et Penture	à Vie	Roller & Hinge	Lifetime

Suite aux conditions et aux termes décrits ci-dessous, Zitta garantit que le produit vendu est conforme à ses spécifications et qu'au moment de la vente, le produit est exempt de tout vice et/ou défaut de fabrication. Cette garantie n'est applicable que pour le premier acheteur-utilisateur et ce pour la première année à partir de la date d'achat. Cette garantie ne peut être transférée à une tierce personne. Cette garantie exclue tout frais relié au déplacement, frais d'installation et/ou désinstallation et aux frais de transport.

La présente garantie ne couvre pas les défauts ou bris résultant d'Acte de Dieu, d'accident, de catastrophe, d'abus, de négligence, d'une installation non conforme, de l'ajout ou de la suppression de pièce ou équipement, d'une mauvaise utilisation, de variation de température intense, d'exposition aux produits chimiques et a des abrasifs de tout genre ou de tache provoquée par différent type d'eau tel une eau ferreuse ou alcaline.

Zitta ne peut être tenu responsable des dommages directs ou indirect causés ou résultant de cas fortuits, des frais de main d'oeuvre, frais divers, perte de temps, matériaux ou autres coûts relatifs à l'application ou au remplacement du produit ou à l'une de ses composantes. Dans l'éventualité ou un défaut de fabrication se manifeste, l'acheteur utilisateur devra avoir suivi les instructions d'installation inscrites au manuel d'instruction, devra présenter une preuve d'achat ainsi qu'une preuve d'installation par un professionnel reconnupar l'industrie de la construction. Zitta pourra a son entière discrétion, réparer ou remplacer le produit sur une base au prorata du prix alors en vigueur. Zitta se réserve le droit de faire inspecter, sur le site, la déféctuosité par un représentant de son choix. Aucun retour ne sera accepté sans l'autorisation au préalable de Zitta.

Entretien et prévention

Zitta recommande l'entretien des surfaces avec un chiffon humide et du savon doux. L'utilisation de produits abrasifs, grattoir, brosse ou tout autres objets pouvant endommager la surface du produit est a proscrire et annulera la présente garantie. Vous référer à la section «Nettoyage» pour des directives spécfliques d'entretien du fabricant.

Following the terms and conditions described below, Zitta warrants the product to be free from defects in workmanship from the date of purchase. This warranty applies to the initial date of purchase from an authorized dealer for the owner/end-user only. This warranty cannot be transferred to a third party. This warranty excludes any expenses related to shipping, handling and/or installation fees.

The present warranty does not cover the defects or breaking resulting from any Act of God, accident, catastrophe, abuse, negligence, improper installation, addition or removal of parts or equipment, of misuse, intensive variation of temperature, exposures to chemicals and/or abrasives of any kind, stains caused by different types of water such as ferrous or alkaline water.

Zitta cannot be held responsible for the direct or indirect damage caused by or resulting from fortuitous occurrences, from the expenses of sundries, labor, wastes of time, material or any other cost related to the application or the replacement of the product or one of its components. In the eventuality that a manufacturing defect appears, the owner/enduser must have followed the instructions of installation described in the installation manual, have in his possession the proof of purchase as well as a proof of installation by a professional recognized by the construction industry.

Zitta will, at its own discretion, repair or replace the product based on the selling price at the time of purchase. Zitta reserves the right to inspect, on site, the defect by a representative of its choice. Any return of goods will not be accepted without the written authorization from Zitta.

Maintenance and prevention

Zitta recommends the use of a wet cloth and soft soap for the maintenance of surfaces. The use of gritting scraper, brushes or any other scouring object which can damage the surface of the product is to be proscribed and will cancel the present warranty. Refer to the "Cleaning" section of the owner's manual for the manufacturer recommendations.



ACRYLINE

Tel: 1-855-492-4242 450-704-2323
Fax: 1-866-735-6885
Info@zittagroup.com
www.zittagroup.com

81, Theodore-Viau, Terrebonne,
Quebec, Canada, J6Y 0J8